

Fractional Parity Turbine Meter Sizes 1/2"-2 1/2"

High Performance Turbine Technology

DESCRIPTION

The Fractional Parity Turbine Flowmeter line exemplifies all the proven and known advanced techniques in the Art of Measurement by the Turbine Principle. The meter's clean lines and simple configuration of components assure higher flow rates, extended flow range and sustained performance capability. The Parity Turbine Flowmeter is designed for use within the guidelines of API Standard; Chapter 5.3, formerly Standard 2534, (The Measurement of Liquid Hydrocarbons by Turbine Meter Systems), and the test procedures of API Standard; Chapter 4, (Prover Systems).

DESIGN FEATURES

- Output linear with flow rate
- Rangeability of 10 to 1
- Explosion proof amplifier housing
- Superior accuracy and repeatability
- Compact design
- Tungsten Carbide Bearing - no lubrication required
- Variety of readout instruments available

PERFORMANCE - Meter

Linearity: $\pm 0.25\%$ (3/4" and 2 1/2" meters); $\pm 0.5\%$ (1/2" meters) of flow rate, on viscosity between 0.3 and 3.0 Centistokes
 Repeatability: 0.04% total
 Flow Range: 10 to 1

MATERIALS OF CONSTRUCTION

Housing: 304 Stainless Steel (Flanged Models)
Rotor Support: 316 Stainless Steel
Rotor: Standard; 17-4 PH Stainless Steel
Bearings: Tungsten Carbide
Shaft: Tungsten Carbide
Thrust Washer: Tungsten Carbide

K-FACTOR

Size	K-Factor (Gallons)
1/2"	13,400
3/4"	4,200
1"	900
1 1/2"	400
2"	180
2 1/2"	100

NOTE: See Model Code for meter options configurations and accessories.



⚠ WARNING

Do not operate this instrument in excess of the specifications listed. Failure to heed this warning could result in serious injury and/or damage to the equipment.

CONNECTIONS

Mechanical: Flowmeters from 1/2" to 2 1/2" sizes are available with ANSI B16.5 R.F. Flanges.

Standard: 150 lb. - 600 lb.
 3/4" - 2 1/2" - DIN PN64, PN100
 1/2" - DIN PN64, PN100
 (See Flange Connections Table)

Optional: 900 lb.

Electrical: All signal and power connections are terminated at screw terminals located in the sensor/preamp housing.

NEC Class 1 Group D, Division 1
 U/L - not available
 CENELEC EExd II CT6, EEx ib II C T4/T6 (85° max) (Note: 3/4" - 2 1/2" only)

Weights & Measures:

CSA - LR 32408 (Pre-amp only)
 CCA - AV-2264 (Consult factory for specific models)

RATINGS

Pressure: ANSI Pressure - Temperature rating corresponding to flanges used.

Temperature:

Standard: -30° to 180°F (-34°C to 82°C)

High Temperature Pick-off: -30° to +400°F (-18°C to 316°C)

(1/2" only) -10°F to 250°F (-20°C to 120°C)

Performance (Pre-amplifier; 3/4" to 2 1/2")

Power Required: 6 to 28Vdc at 20mA maximum

Input Sensitivity: 15 mV minimum

Output Signal: 0 to 5V pulsating dc, TTL compatible or pulse amplitude = $V_s - 1.5V_{dc}$

Transmission distance: 3000ft. (Belden 8770 or equivalent)

Frequency Range: 4 Hz to 10 KHz

Temperature: -30°F to 185°F (-34°C to 85°C)

PICK-OFF SPECIFICATIONS - 3/4" to 2 1/2"

Type: Reluctance

Output: 15 to 20 mVac at minimum flow; 2 to 3 Vac at maximum flow

Performance (RF Sensor; 1/2" meter only)

Power Required: 10 to 18Vdc at 15mA maximum

Output Signal: Open Drain with 3.3K ohm internal pull-up to $V_s - 1V_{dc}$

Vol: 0.4Vdc max at $I_{ol} = 20mA$

Voh: 0.95 ($V_s - 1V_{dc}$) min

Frequency Range: 4 Hz to 3 KHz

Temperature: -13°F to 240°F (-25°C to 115°C)

FLOW RANGE

Products having a specific gravity of 0.7 to 1.0 and a viscosity of 0.3 to 3.0 cst

Size	Standard	Extended	Standard	Extended	Pressure	
	Flow Range GPM	Flow Range GPM	Flow Range LPM	Flow Range LPM	psi	kPa
1/2"	0.7 - 7.0	7.0	2.65 - 26.5	26.5	8	55
3/4"	2.0 - 20.0	25.0	7.57 - 75.7	94.6	9	62
1"	7.0 - 70.0	88.0	26.5 - 265	333	14	97
1 1/2"	15.0 - 150.0	188.0	56.8 - 568	712	9	62
2"	30.0 - 300.0	375.0	113.6 - 1136	1419	7	48
2 1/2"	50.0 - 500.0	625.0	189.3 - 1893	2366	10	69

Flow Rate Adjustment Factor for Specific Gravity

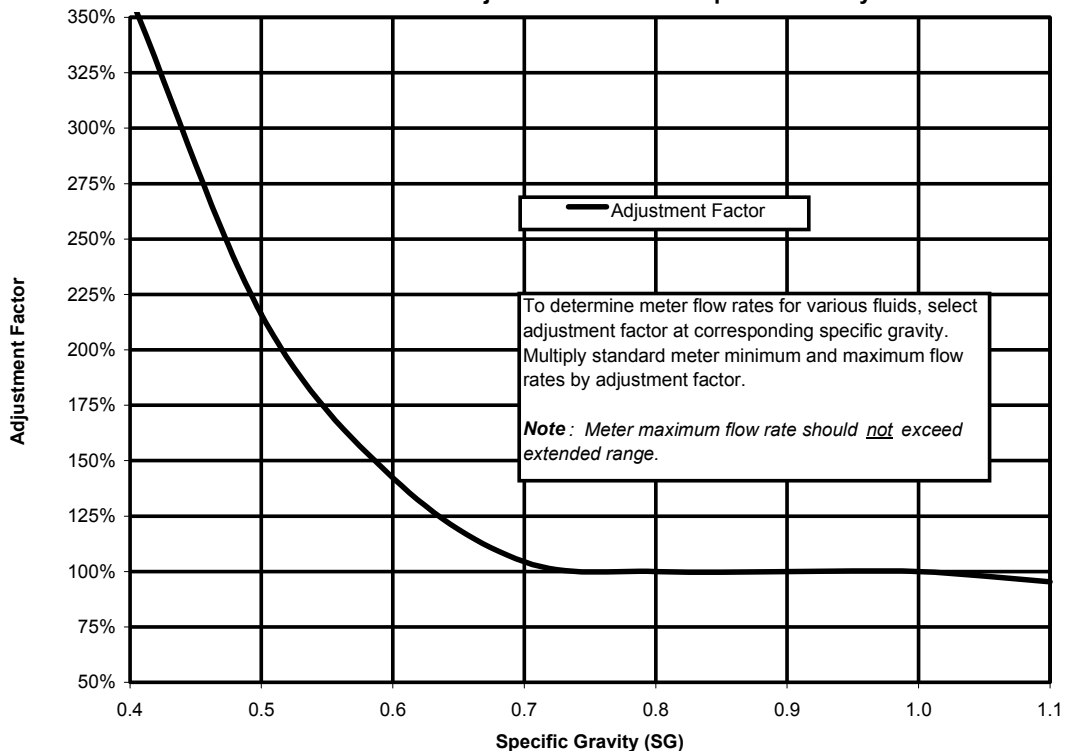

FLANGE CONNECTIONS

MODEL	ANSI Connections	MAXIMUM WORKING PRESSURE @ 100°F		DIN Connections	MAXIMUM WORKING PRESSURE
		Stainless Steel	Carbon Steel		
T81	1/2", 150 lb. ANSI	275 psi	285 psi	DN 15 PN 40	40 Bar
T81	1/2", 300 lb. ANSI	720 psi	740 psi	DN 15 PN 64	64 Bar
T81	1/2", 600 lb. ANSI	1,440 psi	1,480 psi	DN 15 PN 100	100 Bar
T87	3/4", 150 lb. ANSI	275 psi	285 psi	DN 20 PN 16	16 Bar
T87	3/4", 300 lb. ANSI	720 psi	740 psi	DN 20 PN 40	40 Bar
T87	3/4", 600 lb. ANSI	1,440 psi	1,480 psi	DN 20 PN 64	64 Bar
T87	3/4", 600 lb. ANSI	1,440 psi	1,480 psi	DN 20 PN 100	100 Bar
T01	1", 150 lb. ANSI	275 psi	285 psi	DN 25 PN 16	16 Bar
T01	1", 300 lb. ANSI	720 psi	740 psi	DN 25 PN 40	40 Bar
T01	1", 600 lb. ANSI	1,440 psi	1,480 psi	DN 25 PN 64	64 Bar
T01	1", 600 lb. ANSI	1,440 psi	1,480 psi	DN 25 PN 100	100 Bar
T15	1 1/2", 150 lb. ANSI	275 psi	285 psi	DN 40 PN 16	16 Bar
T15	1 1/2", 300 lb. ANSI	720 psi	740 psi	DN 40 PN 25	25 Bar
T15	1 1/2", 300 lb. ANSI	720 psi	740 psi	DN 40 PN 40	40 Bar
T15	1 1/2", 300 lb. ANSI	720 psi	740 psi	DN 40 PN 64	64 Bar
T15	1 1/2", 600 lb. ANSI	1,440 psi	1,480 psi	DN 40 PN 100	100 Bar
T02	2", 150 lb. ANSI	275 psi	285 psi	DN 50 PN 16	16 Bar
T02	2", 300 lb. ANSI	720 psi	740 psi	DN 50 PN 25	25 Bar
T02	2", 300 lb. ANSI	720 psi	740 psi	DN 50 PN 40	40 Bar
T02	2", 300 lb. ANSI	720 psi	740 psi	DN 50 PN 64	64 Bar
T02	2", 600 lb. ANSI	1,440 psi	1,480 psi	DN 50 PN 100	100 Bar
T25	2 1/2", 150 lb. ANSI	275 psi	285 psi	DN 65 PN 16	16 Bar
T25	2 1/2", 300 lb. ANSI	720 psi	740 psi	DN 65 PN 25	25 Bar
T25	2 1/2", 300 lb. ANSI	720 psi	740 psi	DN 65 PN 40	40 Bar
T25	2 1/2", 300 lb. ANSI	720 psi	740 psi	DN 65 PN 64	64 Bar
T25	2 1/2", 600 lb. ANSI	1,440 psi	1,480 psi	DN 65 PN 100	100 Bar

SHIPPING WEIGHT AND VOLUME (Approximate)

Meter	150 lbs.				300 lbs.				600 lbs.			
	lbs.	Kg.	Cu. Ft.	Cu. Mtr.	lbs.	Kg.	Cu. Ft.	Cu. Mtr.	lbs.	Kg.	Cu. Ft.	Cu. Mtr.
1/2"	6	2.72	0.31	0.008	8	3.63	0.36	0.01	10	4.54	0.36	0.01
3/4"	7	3.18	0.33	0.009	9	4.08	0.39	0.011	11	4.99	0.39	0.011
1"	9	4.08	0.45	0.013	11	4.99	0.53	0.015	14	6.35	0.53	0.015
1 1/2"	14	6.35	0.58	0.02	19	8.62	0.71	0.02	24	8.62	0.71	0.02
2"	19	8.62	0.71	0.02	23	10.43	0.8	0.022	28	12.7	0.8	0.022
2 1/2"	25	11.34	0.86	0.024	30	13.61	1.02	0.028	38	17.24	1.02	0.028

DIMENSIONS - (For Certified Dimension Prints - Consult Factory)

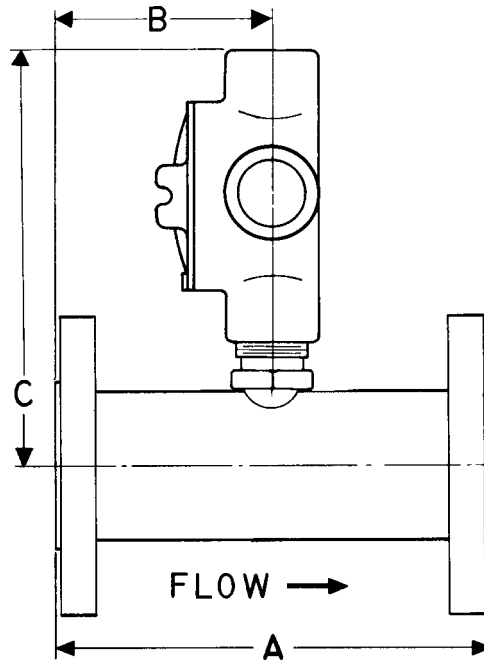

Meter Size	ANSI R.F. FLANGES					
	A		B		C	
	Inches	mm	Inches	mm	Inches	mm
1/2"	5 1/2	140	2 3/4	70	7	178
3/4"	5 1/2	140	2 3/4	70	8	203
1"	8	203	3	76	8 7/16	214
1 1/2"	9	229	3 1/2	89	8 11/16	221
2"	9	229	3 3/4	95	9 3/32	231
2 1/2"	9	229	4 1/2	114	9 9/16	243

The contents of this publication are presented for informational purposes only, and while every effort has been made to ensure their accuracy, they are not to be construed as warranties or guarantees, express or implied, regarding the products or services described herein or their use or applicability. We reserve the right to modify or improve the designs or specifications of such products at any time without notice.



Daniel Division Headquarters - Houston, Texas, USA, Tel: (713) 467-6000, Fax: (713) 827-3880

USA Toll Free 1-888-FLOW-001

Calgary, Alberta, Canada, Tel: (403) 279-1879, Fax: (403) 236-1337

Stirling, Scotland - UK, Mid-East & Africa, Tel: +44 1653-638300, Fax: +44 1653-600425

Singapore - Asia Pacific Tel: +65- 777-8211, Fax: +65- 770-8001

Daniel is a wholly owned subsidiary of Emerson, and a division of Emerson Process Management.

www.daniel.com