

Model 750

PRESSURE REDUCING VALVES

DESCRIPTION

The Model 750 pressure reducing valve is designed to regulate downstream pressure within ± 2 psi (13.8 kPa) or better, regardless of variation in flow rate or upstream pressure. The pilots are balanced, single seated valves with large ports and are not affected by variations in upstream pressure.

DESIGN FEATURES

- Modular construction - all internal parts including seat ring can be removed with the cylinder assembly without disturbing line connections.
- No diaphragms or stuffing boxes
- 45° body design assures high capacity
- Positive shut-off
- Uniform speed of response
- Linear control characteristics
- Inherently checks reverse flow
- O-Ring plus metal-metal seat

APPLICATIONS

- Distribution systems
- Meter over-pressurization protection
- Pipeline delivery to storage
- Pump suction pressure control (positive NPSH)

"AP" (AGGRESSIVE PRODUCTS) OPTION

The "AP" option valve cylinder incorporates a combination of seals and O-ring materials to provide optimum performance in aggressive product applications. This option includes reinforced cylinder heads, stat-o-seals, washers and gaskets. Specify "AP" Option at time of order when used on alcohols, MTBE, TAME and reformulated fuels.



⚠ WARNING

Do not operate this instrument in excess of the specifications listed. Failure to heed this warning could result in serious injury and/or damage to the equipment.

PRINCIPLE OF OPERATION

The valves are pilot operated and operate on a balanced piston principle, spring biased to a closed position. Pressure differential overcomes the force of the spring, causing the main valve to open and establish flow. The pilot control(s) vary the pressure on the spring side of the piston for position.

FLANGE CONNECTIONS / RATINGS (DIN)

Valve Size	DIN PN16	DIN PN25	DIN PN40	DIN PN64 (300 lbs.)	DIN PN64 (800 lbs.)	DIN PN100
	MAX. WORKING PRESSURE @ 120°C	MAX. WORKING PRESSURE @ 120°C	MAX. WORKING PRESSURE @ 120°C	MAX. WORKING PRESSURE @ 38°C	MAX. WORKING PRESSURE @ 120°C	MAX. WORKING PRESSURE @ 38°C
DN50 - DN300	16 bar	25 bar	40 bar	51 bar	64 bar	100 bar

Temperature Range: -20°F to 150°F (-29°C to 66°C) Optional 250°F (121°C)

FLANGE CONNECTIONS / RATINGS (ANSI)

Valve Size	MAXIMUM WORKING PRESSURE @ 100° F		
	150 lbs. ANSI	300 lbs. ANSI	600 lbs. ANSI
2" - 12"	285 psi	740 psi	1480 psi

MATERIALS OF CONSTRUCTION

Main Valve Body

Steel - ASTM-A216-GR-WCB

Main Valve Cylinder

2-4" Stainless Steel on 150lb. and 300lb. valves.

6-12" Steel, Nickel Coated on 150lb. and 300lb. valves.

Main Valve Piston

2-6" Stainless Steel on 150lb. and 300lb. valves.

Stainless Steel Standard on 600lb. valves.

Seat Ring

2-8" Stainless Steel

8-12" Steel, Nickel Coated

Stainless Steel on 600lb. valves.

O-Rings

Standard - Buna-N

Optional - Other O-Rings are available Neoprene[†],
 EPR, all Viton[®], all Buna-N, Kalrez/Teflon ("AP"

Valves)

Other Internal Parts

Stainless Steel

Pilot Valve Strainer/Needle Valve Body

Standard - Steel

Pilot Valve Strainer/Needle Valve Trim

Stainless Steel

Tubing and Fittings

Standard - Steel

Optional - Stainless Steel

PRESSURE DROP

Refer to Publication DSVALVEC_v.

VALVE CAPACITY DATA

Valve Size	2"	3"	4"	6"	8"	10"	12"
*C _v - gpm	86	186	309	688	1296	2040	2,920

For capacities and pressure drops, please consult Publication DSVALVEC_v "Capacity Charts for Valve Sizing."

*C_v based on wide open valve utilizing water at 60°F (15.6°C).

OPTIONAL EQUIPMENT

1. Valve Position Indicator
2. Stainless Steel Position Indicator - (Visual Only)
3. Position Indicator Switches
4. Stainless Steel Main Valve Piston
5. Independent Opening Speed Control
6. Stainless Steel Tubing
7. Thermal Relief
8. Additional Pilot Control Functions
9. Excess Flow Shutoff (Pressure Sensitive)
10. Pilot Line Isolation Block Valves
11. Manual Override (Opens Valve)
12. Epoxy coating main valve body unmachined surfaces

RECOMMENDED SPARE PARTS

O-Rings

PILOT SPRING RANGES

150 - 300 lb. Valves		600 lb. Valves	
(psi)	(kPa)	(psi)	(kPa)
0 - 20	0 - 138	*5 - 100	345 - 690
*0 - 40	0 - 276	50 - 250	345 - 1724
30 - 80	207 - 552	200 - 400	1379 - 2758
70 - 180	483 - 1241	350 - 650	2413 - 4482
150 - 350	1034 - 2413	600 - 950	4137 - 6550
350 - 650	2413 - 4482	900 - 1500	6205 - 10342

* Spring selection based on control pressure set point.

SHIPPING WEIGHTS AND VOLUME (Approximate)

Size	150-300 lb. (ANSI Fig.)		600 lb. (ANSI Fig.)		150-300 lb. (ANSI Fig.)		600 lb. (ANSI Fig.)	
	lbs.	Kg.	lbs.	Kg.	Cubic Feet	Cubic Meters	Cubic Feet	Cubic Meters
2"	60	27.22	100	45.36	1.66	0.047	1.79	0.051
3"	105	47.63	150	68.04	2.36	0.067	2.5	0.071
4"	140	63.5	205	92.99	2.51	0.071	3.13	0.089
6"	250	113.4	400	181.44	4.84	0.137	6.07	0.172
8"	465	210.92	725	328.85	8.94	0.253	9.98	0.283
10"	700	317.51	1170	530.7	12.08	0.342	15.13	0.428
12"	1251	551.11	1820	825.54	20.25	0.573	21.94	0.621

TYPICAL INSTALLATIONS

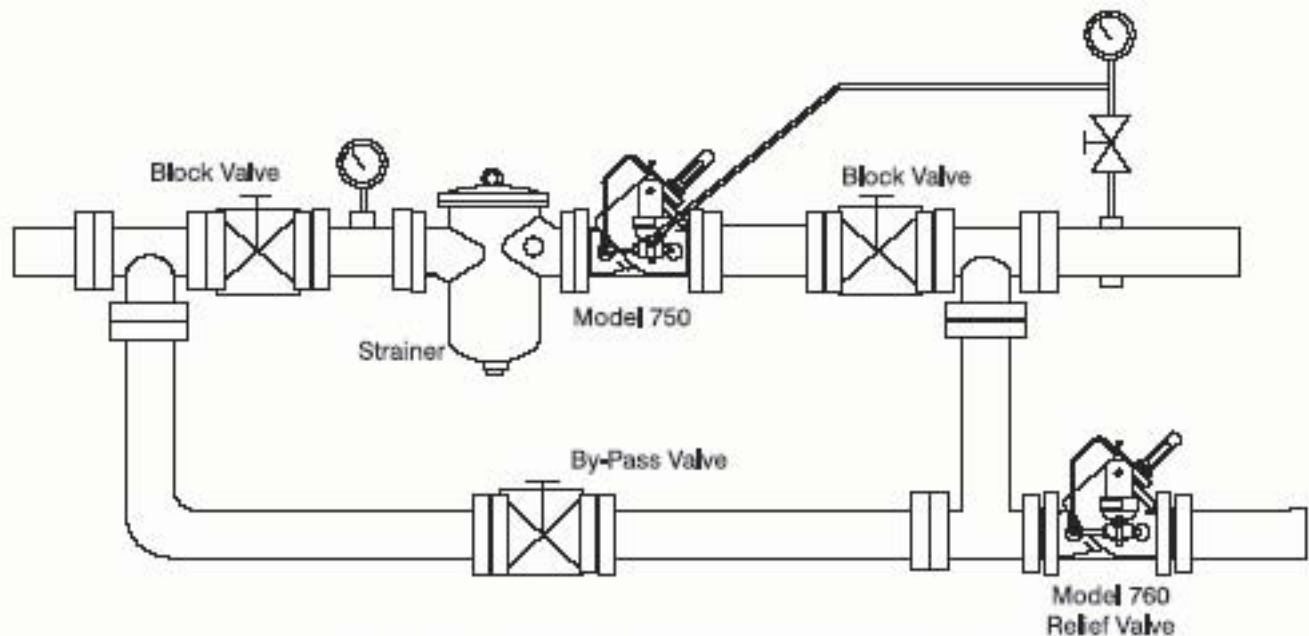

Figure 1 - This drawing illustrates the most common usage of the pressure reducing control valve. The Model 750 externally sensed to any point downstream, provides a sensitive control for regulation of pressure within ± 2 psi (13.8 kPa). The Model 760 back pressure control valve, acting as a relief valve, protects the system if excessive pressure or surge occurs.

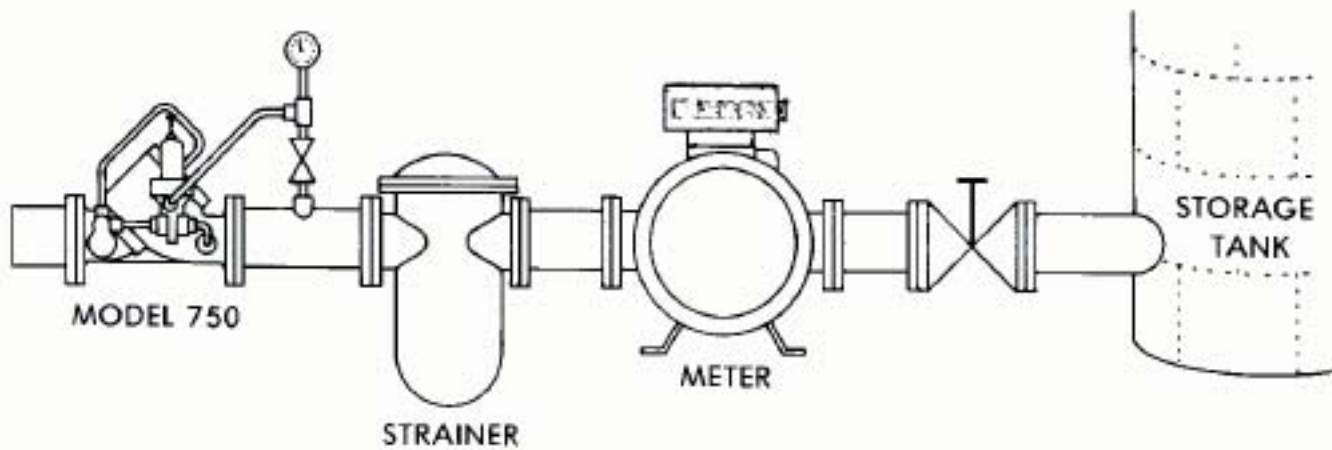

Figure 2 - In this application the Model 750 pressure reducing valve lowers main pipeline pressure to a level that is within the acceptable rating of the metering equipment. The pressure reducing valve will control a maximum reduced pressure drop of 1000 psi (8895 kPa).

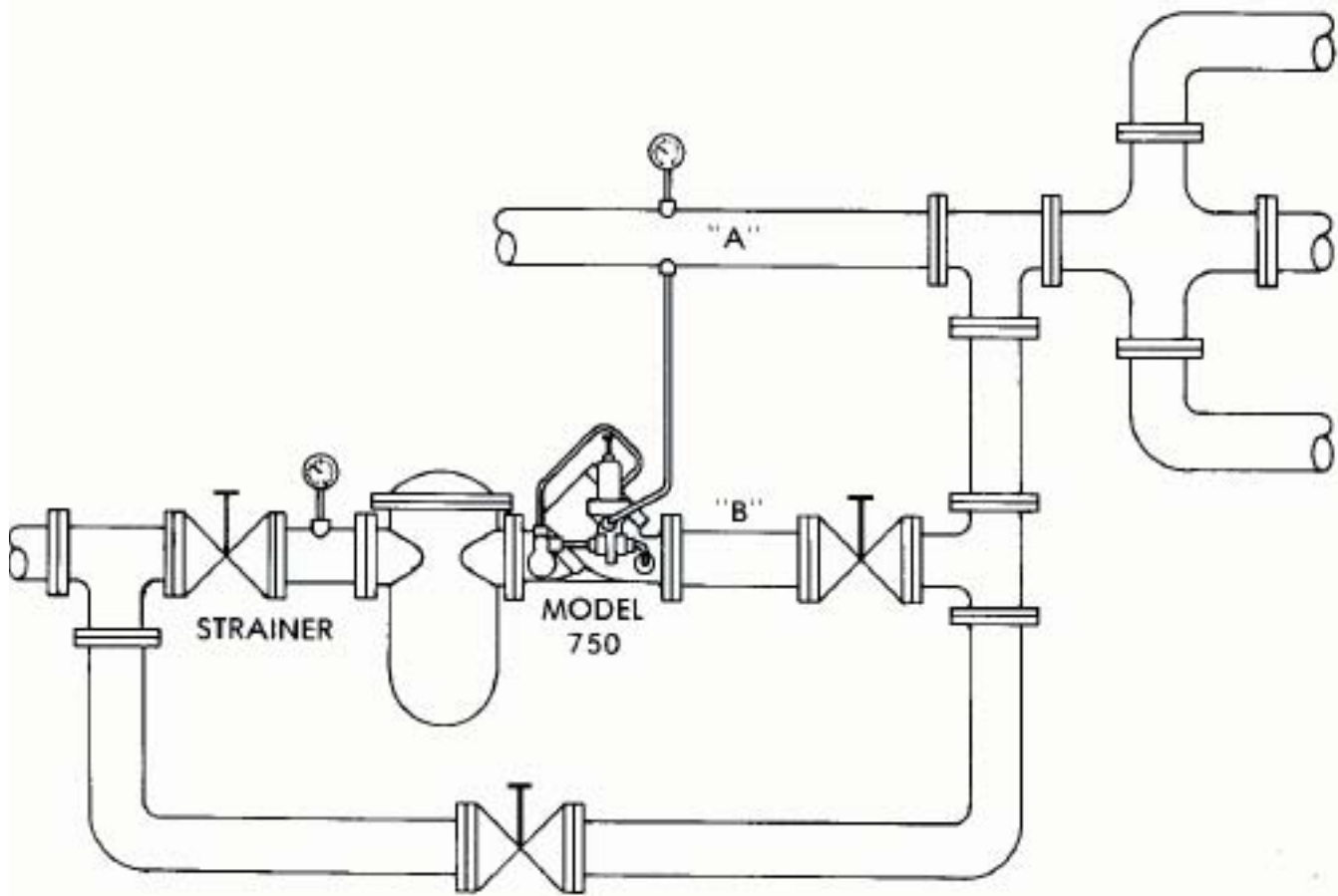
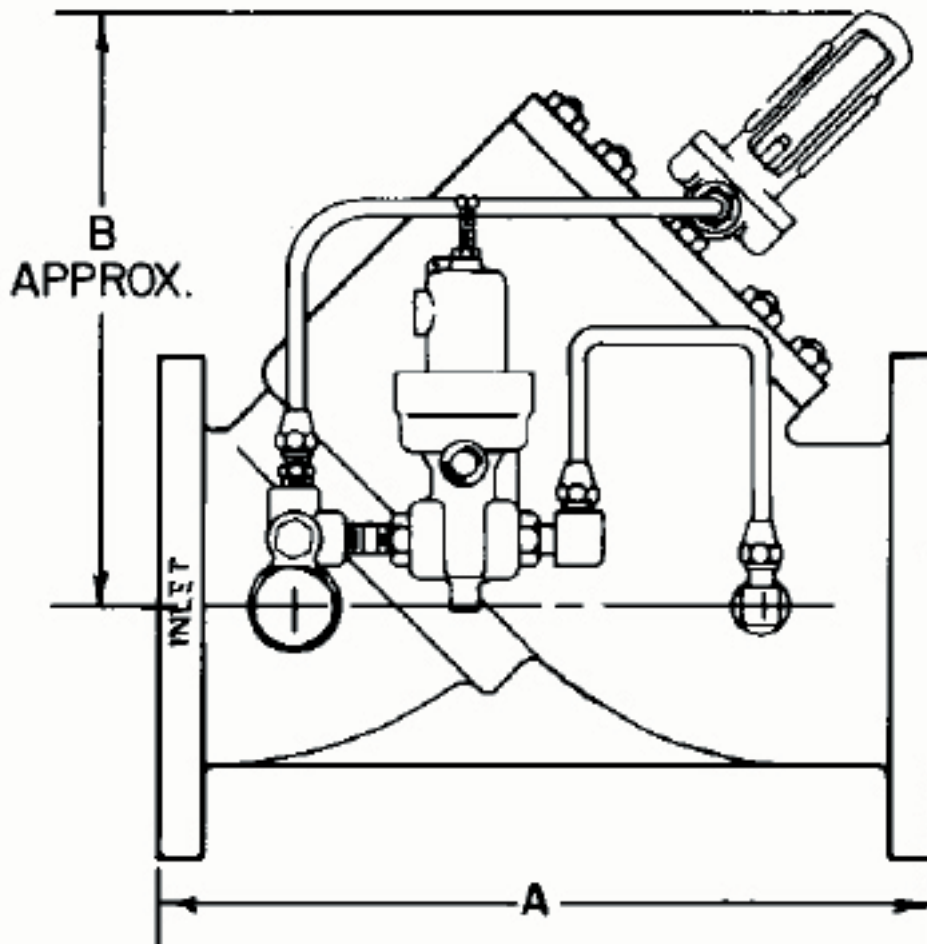

Figure 3 - Pipeline "A" normally provides all product for distribution unless pressure drops below a required minimum. At this time the Model 750 installed in an auxiliary line "B" and sensed to the main line "A", opens to maintain pressure and flow until normal main line pressure is restored.

DIMENSIONS (For certified dimension prints - consult factory)



Valve Size	DIMENSION A (ANSI Flanges)						DIMENSION B (ANSI Flanges)	
	150 lbs.		300 lbs.		600 lbs.		150-600 lb.	
	Inches	mm	Inches	mm	Inches	mm	Inches	mm
2"	10 1/4	260	10 1/2	267	11 1/2	292	10 7/8	278
3"	11	279	13 1/8	333	14	356	11 1/4	290
4"	13	330	14 1/2	368	17	432	11 1/2	292
6"	17	432	17 7/8	454	22	559	13 5/8	348
8"	22 1/4	565	23 1/4	591	26	660	17 3/4	451
10"	26 1/2	673	27 7/8	708	31	787	20 5/8	524
12"	30 7/8	784	33 5/8	854	36 1/2	927	22 7/8	581

PURCHASE SPECIFICATIONS

These valves shall maintain a constant downstream pressure regardless of variation in flow rate or upstream pressure. They shall be hydraulically operated and pilot controlled using the flowing stream as the operating medium. The main valves shall be pressure balanced, single seated, piston operated with 45° body construction. All internal parts, including cylinder, spring, piston and seat ring shall be removed as a cartridge assembly without disturbing line connections. The pilot valves shall be pressure balanced, piston operated and single seated. A manual flow control valve shall be included in the pilot supply line of the 750 to provide an adjustable closing rate. The 750 pilot supply shall also include a strainer. These valves shall, in all respects, be similar or equal to a 750 pressure reducing valve.

ORDERING INFORMATION

When ordering, the following information must be supplied:

1. Size
2. Flange connections
3. Product, product viscosity, product specific gravity
4. Minimum and maximum operating temperature
5. Minimum and maximum flow rate
6. Minimum, normal and maximum operating pressure
7. Control functions to be performed
8. O-Ring material
9. Control pilot materials
10. Tubing material
11. Main valve piston material
12. Pilot spring range
13. Pilot spring setting (psi or kPa)
14. Voltage Required

The contents of this publication are presented for informational purposes only, and while every effort has been made to ensure their accuracy, they are not to be construed as warranties or guarantees, express or implied, regarding the products or services described herein or their use or applicability. We reserve the right to modify or improve

DANIEL

Daniel Division Headquarters - Houston, Texas, USA, Tel: (713) 467-6000, Fax: (713) 827-3880

USA Toll Free 1-888-FLOW-001

Calgary, Alberta, Canada, Tel: (403) 279-1879, Fax: (403) 236-1337

Stirling, Scotland - UK, Mid-East & Africa, Tel: +44 1653-638300, Fax: +44 1653-600425

Singapore - Asia Pacific Tel: +65- 777-8211, Fax: +65 -770-8001

www.daniel.com

Daniel is a wholly owned subsidiary of Emerson , and a division of Emerson Process Management.