

Application Guide

DAN-LIQ-IEB-0306

March 2006

An Introduction to Ethanol Blending



Application Guide

DAN-LIQ-IEB-0306

March 2006

CONTENTS

1. Ethanol Market – Fuels Alcohol Metering and Custody Transfer
2. Ethanol Blending Techniques
3. Skid Mounted 2 - 4 Stream Blenders
4. Blend Stream Measurement and Control Equipment
 - a. Turbine Meter
 - b. Teflon Rotor Notes
 - c. Digital Control Valve
5. Customer Application Questionnaire



1 1/2" SERIES 1200 TURBINE

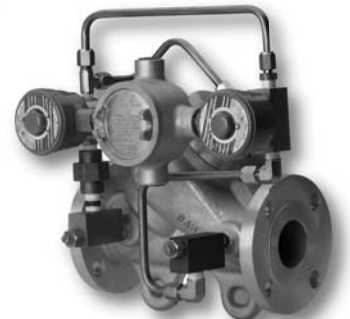

2" V788 VALVE



DANLOAD 6000 PRESET

ETHANOL MARKET - FUELS ALCOHOL METERING AND CUSTODY TRANSFER

A Background To Ethanol Fuels

The increase in demand for agriculturally produced alcohol has increased dramatically over the past few years. The demand has been driven by governmental regulations and mandates for oxygenated fuels, the demise of MTBE as an acceptable oxygenate and the increasing demand for alternative, clean burning fuels.

World consumption of ethanol, the principal fuel alcohol used today, is likely to expand threefold in the next fifteen years, with development of ethanol production plants in every major energy economy. Increasing concerns over the security of oil supplies and pressure from indigenous farm lobbies will drive the use of ethanol and fuel alcohols to ever higher levels.

Ethanol for fuel is produced from a fermentation process using starch or sugar crops as the feedstock, and legislation normally mandates that a denaturant is added, rendering the liquid unsafe for consumption and thus free of certain duties.

The denaturant is often gasoline, but may be other liquids compatible with use as an automobile fuel, and such material as rubber solvents have been used.

Ethanol is a clear liquid with a specific gravity of 0.796 (gasoline is 0.72-0.78) and a viscosity of 1.19cP, compared with gasoline at 0.4cP. It is soluble and readily absorbs water, which present certain challenges to the fuels industry.

Ethanol is normally stored as E95, that is a blend of 5% denaturant (typically gasoline) and 95% ethanol. This is then normally blended at the load rack with gasoline to produce E10, or a blend with 10% ethanol and 90% gasoline.

The limitations on the blend ratios are currently driven by the automotive industry and the technologies used for automotive engines – most engine manufacturers are reluctant to approve the use of blends above E10. E10 is the normal blend in the US, and in Europe E05 is used. In Brazil E85 and E95 fuels are used, and the “flex fuel” technology to allow the use of these fuels is readily available. The introduction of flex fuel engines will increase the consumption of ethanol by allowing the common use of fuels with higher ethanol contents. (Although there are certain other environmental issues such as higher evaporative losses with high ethanol blends which will challenge the industry).

What is certain is that the US domestic consumption of ethanol will increase dramatically from 2.3 billion gallons per year today. The recent Renewable Fuels Standard calls for 7.5 billion gallons per year in 2012.

ETHANOL MARKET - FUELS ALCOHOL METERING AND CUSTODY TRANSFER

Metering And Flow Control Of Ethanol

In general, the metering and custody transfer of fuels alcohol is no different from any other refined liquid product. However, due to the nature of fuels alcohol, there are differences which should be acknowledged.

In order to accurately and reliably meter and control fuels alcohol in custody transfer applications, it is imperative to understand the product and what comprises fuels alcohol. This understanding is critical for the selection of elastomers, computation of net quantities, methods of storage and the best method of loading trucks and railcars.

The use of both turbine and positive displacement meters is well documented in fuel alcohol measurement. Certain ethanol products have a propensity to leave sticky deposits on pipes and instrumentation, which can have an adverse effect on measurement accuracy. Probably the best solution is to use a flowmeter with surface treatment on critical areas so that the deposit does not adhere, thus ensuring that meter calibration is not affected.

A turbine meter with a Teflon coated rotor is best used in these problematic applications, with the coating preventing buildup of deposits and not impacting meter performance or longevity.

Most elastomer materials charts will show that the best elastomer for use with alcohol is EPDM. It must be understood that denatured fuels alcohol is not truly alcohol. For fuels alcohol, EPDM may be far from the best elastomer selection. Due to the denaturant, EPDM may swell and lock up a valve or the valve pilots. Additionally, if the alcohol and denaturant are blended in a sequential blending mode rather than as a stored product, the effect of the denaturant on the elastomers may be immediate rather than over time.

Due to the aggressive nature of the fuels alcohol, it is common to use the "AP" (aggressive products) option for the Daniel digital valve. This has proven a reliable option in many such difficult applications, and the use of Teflon ball seals provides a highly chemical resistant and durable device.

Field experience has shown that a very good elastomer, static and dynamic, for use with fuels alcohol is low swell nitrile. This has proven to be reliable and gives excellent performance and longevity.

Finally, caution must be taken when determining the thermal coefficient of expansion for the computation of "net" volume. It has been found that there are three (3) expansion coefficient tables in use across the USA as well as the use of API tables. The common coefficients of expansion in use are: 0.00063/°F and 0.00062/°F. API Table 6B is also in common use and the "alpha" factor may vary widely. When configuring the preset, it is highly recommended that the local Department of Weights and Measures be contacted to determine the table and expansion coefficient used by them and use the same coefficient. This will insure that proving, placing in service and certification will go smoothly. It must be remembered, however, none of the tables are correct as they apply to pure alcohol and not to a variety of blends. The tables will only provide accurate results for small (1,000 gallons or less) proving volumes.



ETHANOL BLENDING TECHNIQUES

Economic, geographical and political imperatives are driving the development and use of ethanol infrastructure.

Terminals are rapidly expanding their facilities to dispense gasoline products blended with ethanol as an oxygen-enhancing additive.

There are currently two ways products are blended at the loading rack.

The first blending method is ratio-blending (in-line blending). In ratio-blending each component of the final blend flows through its own individual meter and is controlled by a dedicated flow control valve. Each individual blend component quantity is measured independently by the meter dedicated to that single component. This method requires one meter and one control valve per blend component.

The second blending method is sequential-blending. In sequential blending all component quantities of the blend are individually measured through the same single meter. To accomplish this, each component of the blend is loaded sequentially, one at a time, until all blend components are dispensed. This method requires a single meter and control valve, and relies on subsequent mixing (for example in a tank-truck compartment) to effect the proper blend.

Existing gasoline loading arms are commonly used with additive injection systems, and have the scope for additional systems for new components in the blend. The objective in ethanol blending is to inject ethanol into the existing product stream. An economical way, with the least effect on existing operations, is to add an ethanol stream, meter and valve and inject into the gasoline product stream upstream of the gasoline measurement point. When ethanol is injected into the gasoline stream the gasoline meter will now measure the blended product and cannot account for just the gasoline component. When ethanol is blended with gasoline, the gross volume of the blend changes due to the expansion of the mix, and simple proportional calculations are not possible. To accurately measure the gasoline-ethanol blend it is important to measure the blended product. This configuration provides that ability. This type of blending is termed "sidestream" or "wildstream" blending.

The SMS should not be used for sidestream blending.

The Danload 6000 is capable of sidestream blending, in both sequential and ratio blending modes. The Petrocount RMS may be used for ratio blending with the tally meter option for this duty.

Definition Of Blending Methods

Sequential Blending

Sequential blending is the loading of one product component at a time through a single flow meter and a single flow control valve. The blend ratio is correct only after all components of the blend have been loaded.

In-line blending (Ratio Blending)

In-line blending is the simultaneous blending and loading of two or more product components. Each component has a dedicated flow meter and flow control valve. In-line blending can be either non-proportional or proportional as described below.

ETHANOL BLENDING TECHNIQUES

In-line non-proportional

In-line non-proportional blending is accomplished by delivering the low-proportion quantity component(s) of the blend at their assigned high (normal) flow rate(s) during the first part of the delivery of the high-proportion component at its high (normal) flow rate. This method of delivery is implemented so that the flow meter for each component is operating near its maximum rated flow rate to assure maximum measurement accuracy for each component in the blend. After the low-proportion quantity component(s) have been delivered, the high-proportion quantity component continues delivery until the blend ratio is attained. The total blend ratio can be in error until the total preset quantity is delivered.

In-Line proportional

In-line proportional blending is accomplished by controlling the ratio between all components at all times during the delivery by controlling the individual flow rate of each component. The ratio of the delivered blend is correct at all times during the delivery. Therefore, the delivery can be stopped at anytime and the delivered blend will be within tolerance.

Note: In-line proportional blending can only be implemented in cases where the proportion of each component in the blend is great enough to permit the component flow meters to all operate above the minimum specified flow rate of each meter during the entire batch loading cycle.

"Wildstream" Blending (WSB)

"Wildstream" blending usually refers to an off-rack blender that supplies blended product to the rack. As an example, regular and premium could be blended to make mid-grade and supplied to the rack.

In most cases the regular flow is the wildstream and flows by demand. The premium is metered and blended into the regular stream based on a meter is the blender regular stream.

"Sidestream" Blending (SSB)

"Sidestream" blending is similar to in-line blending except one product component is delivered upstream to another product component.

"Sidestream" blending is typically used to inject ethanol into gasoline. Ethanol is injected into the gasoline stream and the blend is measured by the custody transfer meter.

"Sidestream" blending can be achieved using proportional or non-proportional blending. Proportional "sidestream" blending difficulties are as follows:

Product flush cannot be achieved easily at the end of a load.

Trying to meet the strict requirement for meters to operate above the minimum specified flow rate is usually very difficulty with proportional blending.

ETHANOL BLENDING TECHNIQUES

SIDE STREAM RATIO BLENDING WITH DANLOAD 6000

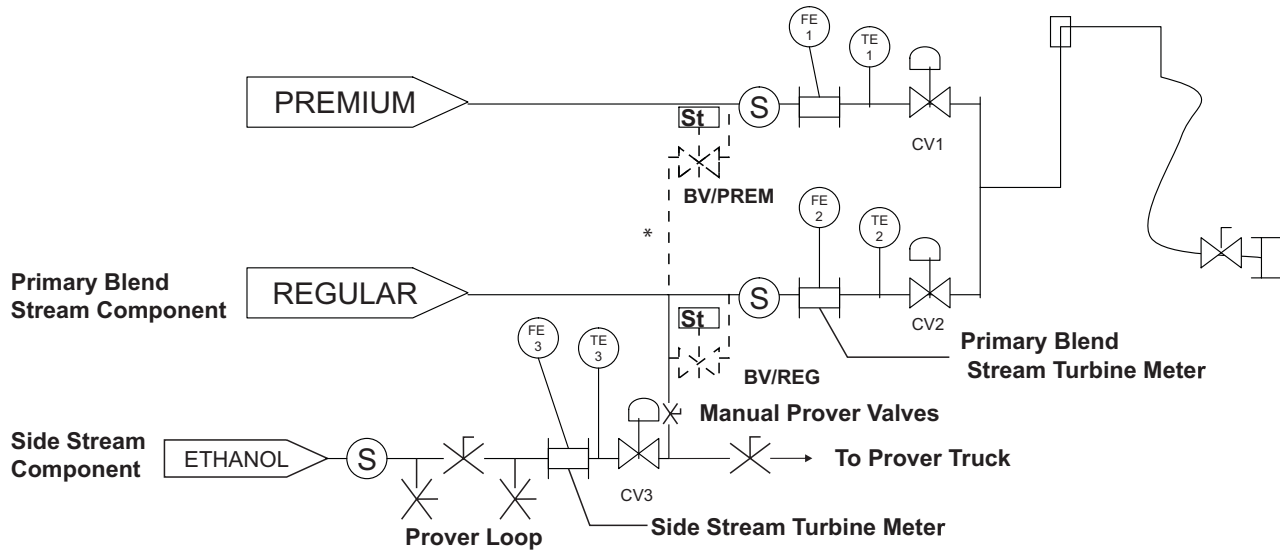

*Optional: share single side stream component w/ 2 products

SIDE STREAM SEQUENTIAL BLENDING WITH DANLOAD 6000

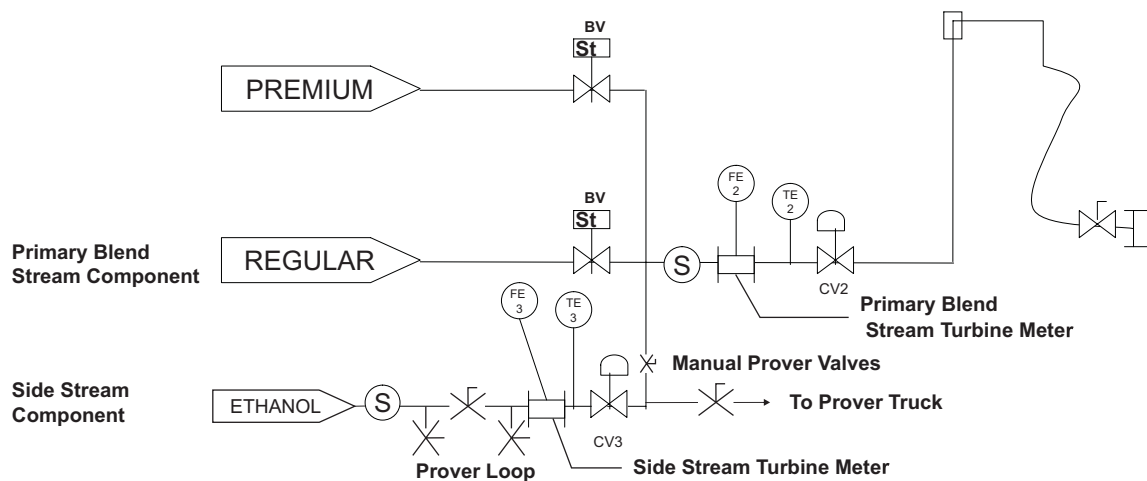

Application Guide

DAN-LIQ-IEB-0306

March 2006

Daniel Skid Mounted One To Four Stream Ethanol Blenders

The space available for new equipment in a load rack gantry is a severe limiting factor when ethanol systems are deployed. New equipment may be supplied loose or as a skid, with skid based systems offering the end user a system which has been tested and prepared so that down-times and commissioning times are minimized.

The supply of skid systems also gives greater control and accountability to the vendor, resulting in the maximum cost-benefit to the terminal operator.

Typical skids have a very small footprint and use flow meters and valves in the vertical. For Series 1200 turbines with flow conditioning plates the normal guidelines for upstream flow conditioning may be negated, and both the Series 1200 turbine meters and 788 DVC valves have been proven in vertical operation.

Typical skids are shown below. The precise skid design is dependent on the space available and the number of blending arms on each bay or island.

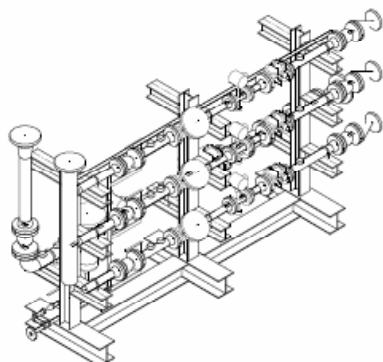
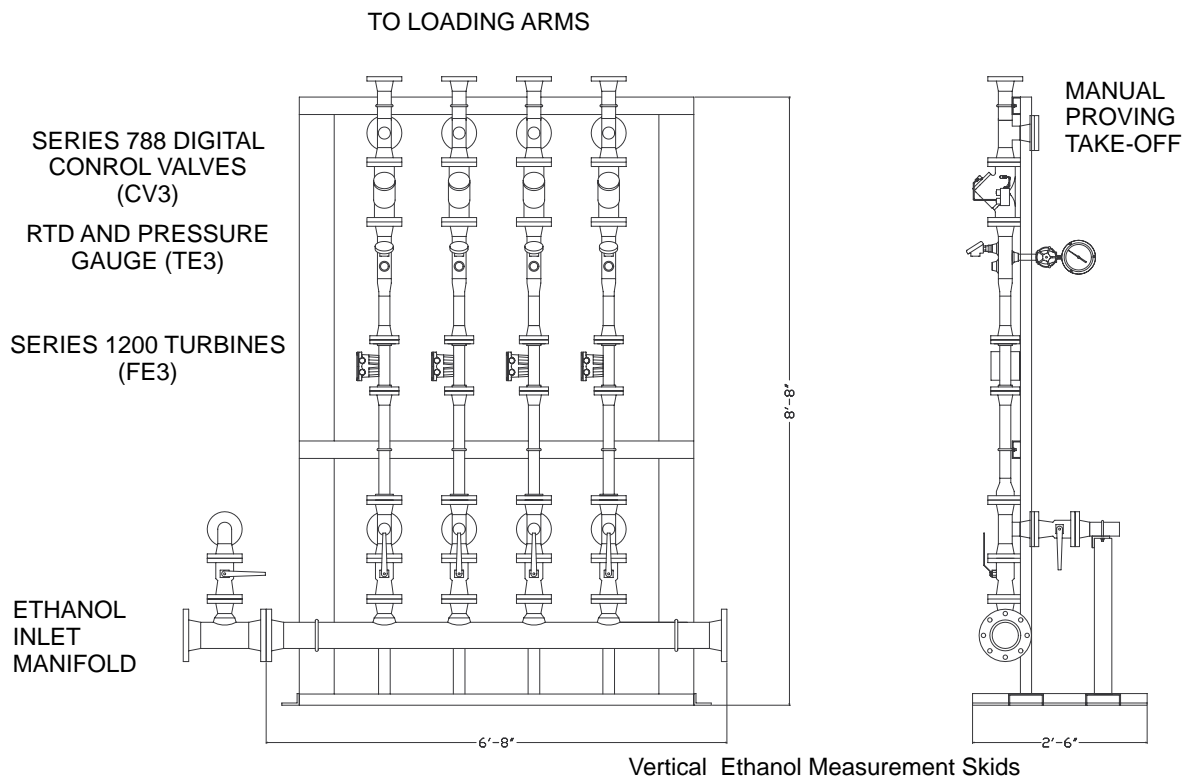

Horizontal Ethanol Measurement Skid



Application Guide

DAN-LIQ-IEB-0306

March 2006

BLEND STREAM MEASUREMENT AND CONTROL EQUIPMENT

a. Turbine Meter - Typical Model Code

➤ 1 1/2" Premium Linearity Series 1200 Turbine Meter With Teflon Coated Rotor

T15AEA2JCBAABGA

SERIES 1200 TURBINE METER

Model Code

T15 – 1.5"

A – 150# ANSI R.F. FLANGES

E – SERIES 1200 SS BEARING

A – 1 PICKOFF, DUAL OUTPUT PREAMP

2 – NTEP, CC"90-118 (FOR EXTENDED FLOW RANGE DOWN TO 6 GPM SEE CERTIFICATE)

J – 0.78 – 0.79 RELATIVE DENSITY/VISCOSITY

C – HORIZONTAL W/ FLOW CONDITIONING PLATE

B – Material of Construction:

----HOUSING: 304 STAINLESS STEEL

----FLANGE: 304 STAINLESS STEEL

---- INTERNALS : SS/ANODIZED AL/BALL BEARING-W/ TEFLON COATED ROTOR

A – NONE – REGISTER TYPE/OUTPUT

A – NONE – REGISTER MOUNTING

B – LINEARITY AND SPECIAL FEATURES: $\pm 0.15\%$ REPEATABILITY $\pm 0.02\%$,

G – UL/CUL (CSA IS COVERED BY UL/CUL)

A – NONE – OTHER DOCUMENTATION



1 1/2" Series 1200 Turbine Meter



1 1/2" Series 1200 Internals

b. Teflon Coated Rotor

Teflon coating of turbine meter rotors has proved to offer significant operational benefits when used with certain types of ethanol.

It has been found that ethanol derived from certain cereal feedstocks deposits a fine layer of material on piping and instrumentation. This does not present a significant problem other than with any device where the cross-sectional area within the device is a process parameter, such as in flow measurement. The conventional liquid turbine meter will see a drift upwards in the K-factor as the cross sectional area presented by the rotor to the flowing stream decreases as the deposit builds up.

It is likely that turbine meters suffering this problem will need more frequent calibration, and it is possible that this will become unfeasible in some conditions.

Coating a turbine meter rotor with Teflon offers a neat solution to this problem. The rotor is dipped in a Teflon bath and the coating is then baked on. The bearing surfaces are protected through this process, so the bearing performance and design is unchanged. The Teflon coat is approximately 1/1000 inch (0.0254mm) and does not have a noticeable effect on the initial performance of the meter.

It does, however, prevent the build-up of the ethanol deposit, and thus ensures repeatable measurement in this demanding application.



Application Guide

DAN-LIQ-IEB-0306

March 2006

BLEND STREAM MEASUREMENT AND CONTROL EQUIPMENT

c. Control Valve - Typical Model Code

➤ 2" 788 DIGITAL CONTROL VALVE

V788BAAR56AAAAE

V788 Digital Control Valve Ethanol

Model Code:

V - Basic Valve Code

788 - Model 788 Digital Control

B - Revision Level

A - Size (2") Low Flow Valve

A - Connections: 2" 150 ANSI

R - Material of Construction:

--- Valve Body: Carbon Steel

--- Piston: Stainless Steel

--- Pilot Body: SS

--- Tubing and Fitting: Carbon Steel SAE

5 - Elastomer:

--- Main Valve Model: AP (Aggressive Product)

--- Main Valve: Teflon (Dynamic) / Low Swell Nitrile (Static)

--- Pilot: All Kalrez (1712 PILOT)

6 - First Spring/Voltage: 110 / 120 VAC

A - Optional Accessory: None

A - Second Spring/Voltage: None

A - Options: None

A - Additional Options: None

E - Approvals: UL/CSA certified electrical components

Note, 2"DCV Valve will control down to 6 GPM .

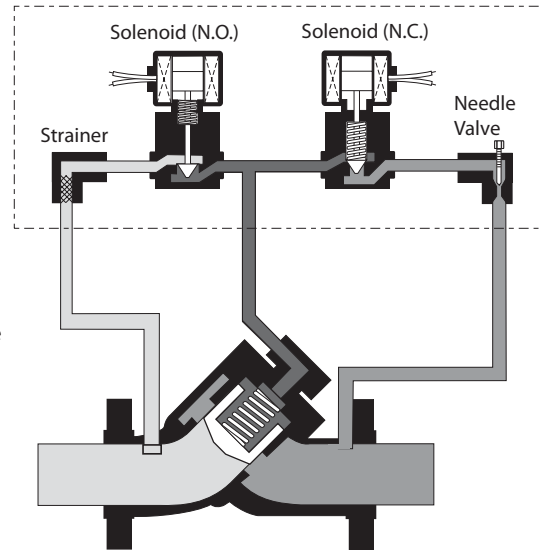
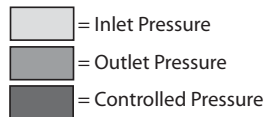

788 DIGITAL VALVE OPERATION

➤ 2" 788 DIGITAL CONTROL VALVE

V788BAARN6AAAAE

V788 Digital Control Valve Ethanol

Model Code:

V - Basic Valve Code

788 - Model 788 Digital Control

B - Revision Level

A - Size (2") Low Flow Valve

A - Connections: 2" 150 ANSI

R - Material of Construction:

--- Valve Body: Carbon Steel

--- Piston: Stainless Steel

--- Pilot Body: SS

--- Tubing and Fitting: Carbon Steel SAE

N - Elastomer:

--- Main Valve Model: AP (Aggressive Product)

--- Main Valve: Teflon (Dynamic) / Low Swell Nitrile (Static)

--- Pilots: All Kalrez (1714 PILOTS)

6 - First Spring/Voltage: 110 / 120 VAC

A - Optional Accessory: None

A - Second Spring/Voltage: None

A - Options: None

A - Additional Options: None

E - Approvals: UL/CSA certified electrical components

Note, 2"DCV Valve will control down to 6 GPM .

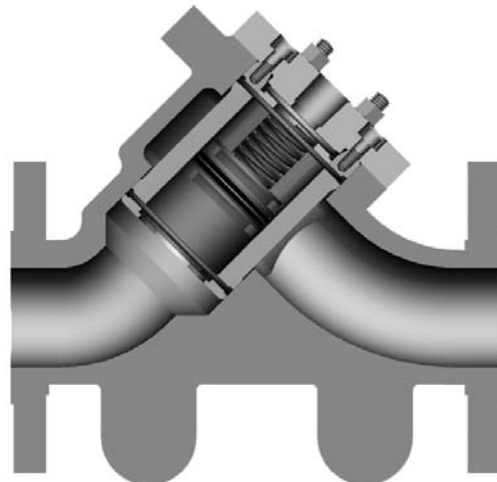

788 VALVE CONSTRUCTION
(AGGRESSIVE PRODUCT OPTION)

Application Guide

DAN-LIQ-IEB-0306

March 2006

CUSTOMER APPLICATION QUESTIONNAIRE

1. How many Islands will have Ethanol Blending? All #

2. How many products on each island will have Ethanol blending?

NOTES BELOW

(1) _____

(2) _____

(3) _____

(4) _____

(5) _____

(6) _____

3. How many islands have MidGrade blending? All #

4. What % Blends will you be loading? 5.7% 7.2%
 10%
 25%
 () Others

5. What are the Minimum and Maximum blended loads in GPM? () Min () Max

6. What flow rates are you loading your main products? () Min () Max

7. What is the Minimum and Maximum flow rate of your Ethanol? () Min () Max

8. Whose Presets are installed at the site? DanLoad 6000

PetroCount
IMS
IMS
RMS
 Accuload
2
3
 TopTech MultiLoad

9. Whose Turbine Meters and (DCV) Valves are installed at the site?
 Daniel
 Daniel/Brooks
 Smith
 Other

10. What type of blending do you presently do if any?
 Sequential
 Ratio
 None

Application Guide

DAN-LIQ-IEB-0306

March 2006

CUSTOMER APPLICATION QUESTIONNAIRE

11. What type of blending will you be doing?

- () Sequential
- () Ratio
- () Side Stream

12. How many additives per Product?

- () Maximum 6 per arm

13. Where is the Engineering being done?

- () Inside Corp Eng
- () Outside Engineering Co.

14. Engineering Contacts and location.

Name: (1) _____

Address: (2) _____

Cell Phone: (3) _____

Phone: (4) _____

Email: (5) _____

Additional Notes:

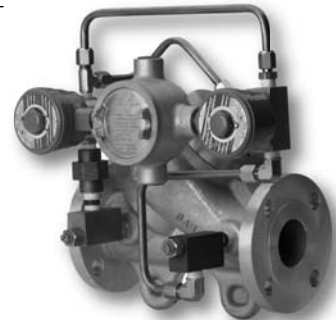

**Emerson Process Management
Daniel Measurement and Control, Inc.,**

**World Area Headquarters
Houston, Texas, USA**

T: 713-467-6000, F: 713-827-3880
USA Toll Free 1-888-FLOW-001
www.daniel.com

Calgary, Alberta, Canada

T: 403-279-1879, F: 403-236-1337

Singapore - Asia Pacific

T: +65-6777-8211, F: +65-6770-8001

Stirling, Scotland - Europe, Mid-East, Africa

T: +44 (0) 1786 433400, F: +44 (0) 1786 433401

Daniel Measurement and Control, Inc. is a wholly owned subsidiary of Emerson Electric Co., and a division of Emerson Process Management. The Daniel name and logo are registered trademarks of Daniel Industries, Inc. The Emerson logo is a registered trademark and service mark of Emerson Electric Co. All other trademarks are the property of their respective companies. The contents of this publication are presented for informational purposes only, and while every effort has been made to ensure their accuracy, they are not to be construed as warranties or guarantees, express or implied, regarding the products or services described herein or their use or applicability. All sales are governed by Daniel's terms and conditions, which are available upon request. We reserve the right to modify or improve the designs or specifications of such products at any time. Daniel does not assume responsibility for the selection, use or maintenance of any product. Responsibility for proper selection, use and maintenance of any Daniel product remains solely with the purchaser and end-user.

DANIEL®

EMERSON™
Process Management