

Ultrasonic Meter Station Design Considerations

JOHN LANSING, Manager, Gas Measurement Technology, Daniel Measurement and Control, Houston, TX

Abstract

The use of ultrasonic meters for custody (fiscal) applications has grown substantially over the past several years. This is due in part to the release of AGA Report No. 9, Measurement of Gas by Multipath Ultrasonic Meters [Ref 1], Measurement Canada's PS-G-E-06 Provisional Ultrasonic Specification [Ref 2], the many diagnostic benefits [Ref 3], and the confidence users have gained in the performance and reliability of ultrasonic meters as primary measurement devices. Just like any metering technology, there are design and operational considerations that need to be addressed in order to achieve optimum performance. The best technology will not provide the expected results if it is not designed and installed correctly, or properly maintained. This paper addresses several issues that the engineer should consider when designing ultrasonic meter installations.

USM Cost Comparison

No discussion about using ultrasonic technology would be complete without addressing installation and maintenance costs. Although this cost comparison with other measurement technologies is dependent upon many variables, the two most important are maximum and minimum anticipated flow rates. Other factors such as bi-directional requirements, operating pressure range, gas temperature, cleanliness of the gas, etc. also influence the decision as to which primary measurement technology is best suited to the application. The actual amount of savings is difficult to quantify without knowing these conditions. Generally speaking, if the operational range for a given application exceeds the capacity of a single meter, using USM technology may significantly reduce the capital expense (CAPEX) associated with the installation.

One reason the number of ultrasonic applications continues to grow is the reduced long-term cost of operation (O&M) and additional diagnostics that are available from this technology as compared to other measurement devices. These benefits have been well

documented in papers presented at several conferences in the past [Ref 3 & 4]. Certainly one of the most significant benefits is the reduction in maintenance. Unlike other technologies, USMs can be diagnosed without taking the meter out of service. In fact, this can be done remotely using LAN/WAN networks via Ethernet, dial-up phones, radios, or other communication techniques. All of these benefits, and many more, often provide the user with significantly lower O&M costs.

Sizing of USMs

Traditional measurement devices have been limited to flow rates that were equivalent to 50-60 feet per second (fps) maximum. Although high-capacity turbines operate in the 80-95 fps range, the majority of installations are still designed for the standard capacity meter. One of the significant advantages of ultrasonic meters is their ability to operate in excess of 100 fps. In replacing orifice meters the "rule-of-thumb" is that the capacity of a single ultrasonic meter is at least 1½ times that of an orifice meter.

Many users specify velocity limits to minimize the potential for piping erosion. This can cause pipeline failure should the wall thickness become too thin. There have been reports by users of severe erosion in elbows downstream of meters that were operated above 100 fps for significant periods of time. Besides piping erosion, there are several other issues that limit high velocity operation.

Higher velocity operation increases the stress on the thermowell(s). Thermowells have cracked when operated at high velocities for extended periods of time. Some work has been performed to determine how accurate the RTD element remains when the thermowell is subjected to very high velocities. It appears vibration of the thermowell can cause the RTD to register higher due to "self-heating" that occurs when the RTD element rubs against the thermowell.

Higher velocities also create more differential pressure across today's high-performance flow conditioners. The magnitude of this loss is somewhat dependent on the type of conditioner installed. Typically the pressure drop at 60 fps is perhaps 3-4 psid differential (psid). If the gas velocity through the meter is increased to 120 fps, the differential becomes 12-16 psid. Straight pipe pressure losses are proportional to the velocity squared, and thus they are often more significant than the loss through the flow conditioner.

The increased velocity and subsequent differential pressure also can create higher noise, both audible and ultrasonic. The ultrasonic noise at these high velocities may begin to interfere with the meter's operation. The audible noise may necessitate additional costs related to noise abatement or possible facility relocation to minimize impact on surrounding environment.

For these reasons, and others, most designers limit normal operation to either 70 or 80 fps. It is tempting to install a smaller meter and operate at higher velocities. However, the additional cost savings of going to these higher velocities can quite possibly be offset by maintenance and reliability problems that may occur later.

Low Flow Performance Issues

USMs traditionally have been sized to operate so that the lowest velocity expected is between 5 and 10 fps. Using 5 fps as the lowest velocity provides a rangeability of 14-1 if the maximum velocity expected is 70 fps. This rangeability is generally better when compared to the traditional orifice and turbine meter. However, larger turbine meters can approach this rangeability (and in some cases exceed this, especially at higher pressures due to increased density). Recently users have been asking how to increase the rangeability in order to help reduce capital costs and O&M costs of the meter station. Since most users limit their maximum velocity to 70-80 fps, the only area left to expand rangeability is to operate the meter at lower velocities.

During the past 2-plus years many users have come to see the value in calibrating meters to velocities as low as 0.5 fps. Calibrating a meter to below 5 fps is often referred to as a "low-flow calibration." Generally 6-8 data points are used for calibrations with a 5-70 fps operational range, with 2 additional data points, often

1 and 3 fps, added for the low flow calibration. By lowering the minimum velocity to 1 fps the user has multiplied the rangeability by a factor of 5!

A typical installation for a gas powered electric generation plant might include a 12-inch meter for the main flow rates, and a 4-inch USM for the lower flow rates. Assuming the lowest the 4-inch is operated is 5 fps, this would equate to about 0.6 fps for the 12-inch meter. This translates into a rangeability of approximately 126-1 by using both meters. Suppose a single 12-inch meter could be operated at this low velocity with a reasonable degree of accuracy. What would be the capital cost savings?

Depending upon the choice of low-flow meter, using a single 12-inch meter would probably save on the order of \$30-50K. By purchasing only one meter, and eliminating the run switching and all the associated piping and control systems, the measurement station is also much easier to maintain. Along with the capital cost reduction, the benefit of less equipment translates into reduced O&M expense for the life of the station. One hidden benefit is with no run switching, the possibility of the main run not activating is eliminated since there are no automated actuators required to open a valve. When a power plant goes online, and they aren't able to get the natural gas they need, this generally causes a loss in revenue, and the end user is not happy with the gas provider.

There are perhaps three major concerns about operating a USM at very low velocities. The first is calibration accuracy, the second is PTZ corrected accuracy, and the third is repeatability. The first accuracy concern is from the absolute performance of the meter. That is, how accurate can the meter be after flow calibration at very low velocities? The second accuracy concern is how accurate will the corrected volume calculation if there is thermal stratification (gas hotter at the top of the meter than at the bottom) within the pipeline? That is, if the gas temperature at the top of the pipe is hotter than the bottom, the temperature sensor will read high, and the corrected volume will then register low.

Both are valid concerns. With today's technology, however, these can be solved very easily. The key questions on accuracy are: "Does the meter provide a method of correction to reduce uncertainty at these very low flow rates, and can thermal stratification be identified?"

First, let's look at how to improve accuracy at very low flow rates. To address the accuracy of a meter, a calibration technique called piece-wise linearization (PWL), commonly used for optimizing turbine meter performance, can be applied within the USM. This technique results in a substantial reduction in the uncertainty at low flow rates. Thus, meter accuracy

can be exceptional once the calibration is complete, and the PWL technique has been implemented. Following is an example of a 12-inch meter that was calibrated from 0.5 fps to 70 fps. If only a single meter factor were applied to this meter, the uncertainty in the lowest velocity data point could not be reduced.

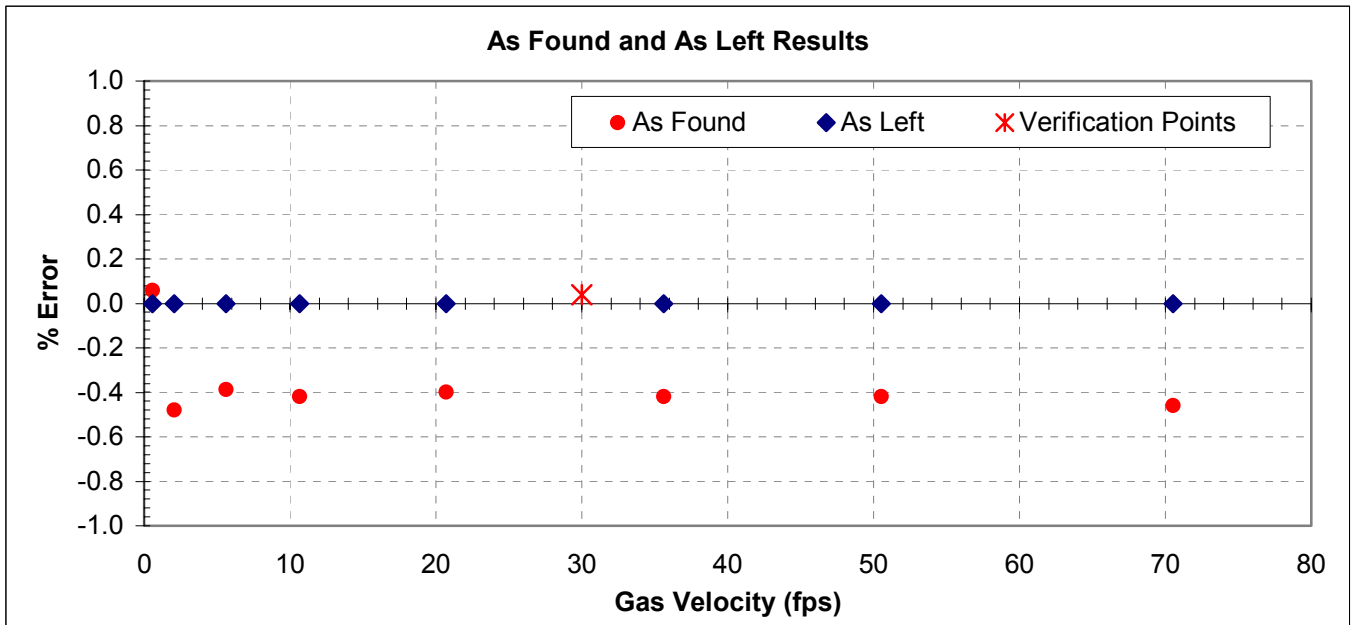

Graph 1 – 12-Inch Meter Calibration Results

As can be seen from this calibration result, the meter's performance at 0.5 fps didn't deviate more than 0.5% from the average of all the other flow rates. It is important to note that even before adjustment, today's USM can easily provide accuracy values much greater than previously thought possible. This is due, in part, to the improvements in dry calibration that have been achieved during the past several years, technological improvements in electronics, and the stability of flow calibration labs.

After implementation of PWL, all errors are driven to zero, so the uncertainty is essentially reduced to a combination of the lab and the meter's repeatability. There is an additional uncertainty when operating between calibration points. This is because the PWL technique assumes the error between calibration points is a straight line. However, by using an appropriate number of data points at the low velocities, this added uncertainty should not exceed 0.1%. This is based

upon calibration results where verifications were taken between flow calibration data points.

The second accuracy concern comes from the possibility of thermal stratification at lower velocities. A previously published paper discussed a 10-inch meter that had thermal stratification on the order of 2 degrees [Ref 4]. This stratification occurred because the gas in the upstream piping was operating at velocities below 3 fps, and there was more than 100 feet of piping exposed to a bright sunlight. Also, there was a significant difference in gas-to-ambient temperature. This is perhaps not a typical installation.

Most designs have upstream piping below ground. Piping will emerge and then make a direction change into the meter. With a 12-inch meter, this typically means 20-25 feet of piping is exposed to the sun and ambient temperature. In this design, even when operating at 1 fps, the gas has less than 25 seconds from the time it exits the elbow or tee, enters the meter

run and then reaches the meter. In 25 seconds it is unlikely for any significant heat transfer to occur and cause temperature induced stratification within the flowing gas. Thus, the tendency for the gas to stratify at these low velocities is very minimal.

If more upstream piping is exposed to ambient and solar effects than in the previous 12-inch meter design example, the potential for thermal stratification increases. However, this phenomenon can be easily detected by looking at the speed of sound reported by a meter that samples transit times horizontally. A higher temperature near the top of the pipe will result in a higher SOS at the meter's upper chord when it is

compared to the lower chord. This SOS differential will normally not be seen when the gas velocity is above 5-10 fps due to the turbulent nature of the flow causing continual mixing. When there is no significant deviation in SOS at the lower velocities, the user can have confidence that there is no thermal stratification, and thus temperature measurement is accurate. The caveat is that not all USM designs can provide this type of information.

To test the theory of thermal stratification, let's look at a typical installation with approximately 25D of upstream piping. Graph 2 below shows a 12-inch meter operated from velocities of 12.5 fps to 1.2 fps.

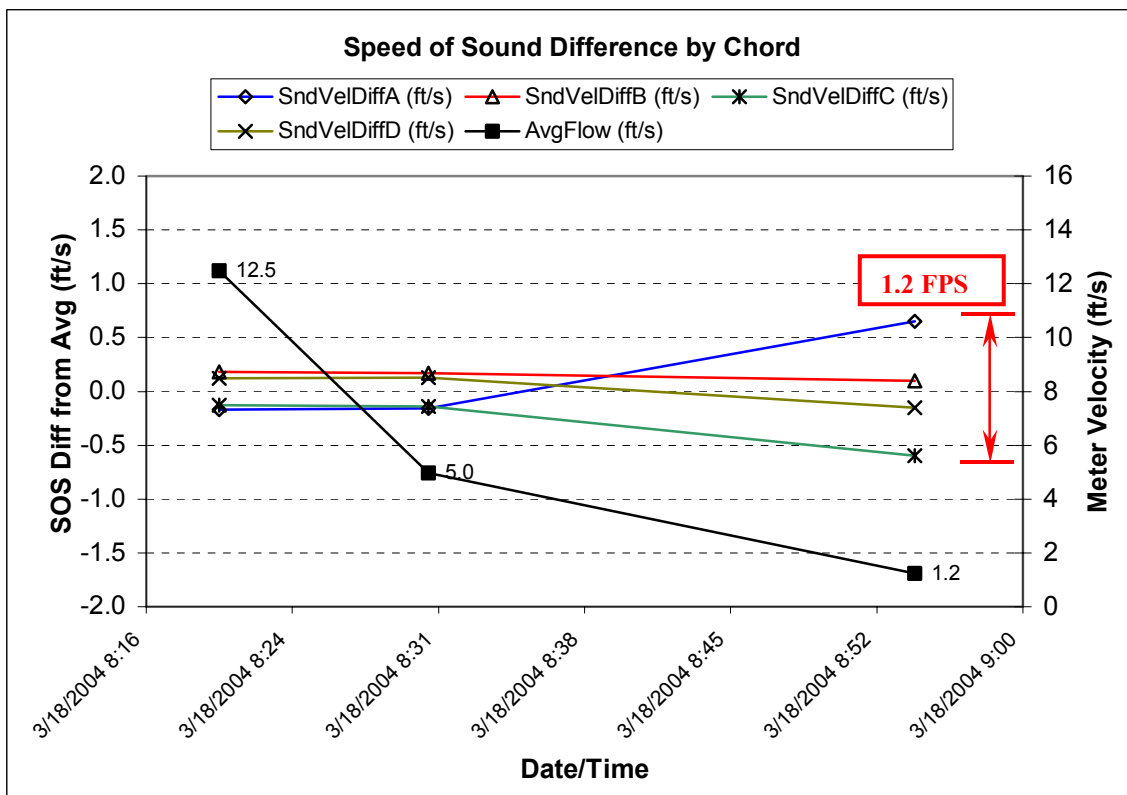

Graph 2 – 12-Inch Meter SOS Spread

The difference in SOS from top to bottom is on the order of 0.4 fps at the higher velocity of 13 fps (left side of the graph). When the meter is operating at 1.3 fps (right side of the graph), the SOS spread is now on the order of 1.2 fps, as shown in Graph 2. This means there is a little thermal stratification within the meter, but this is relatively small. For every degree F of thermal stratification this would translate into a SOS change of about 1.7 fps. In this example one could

determine the stratification effects to be on the order of 0.5-0.7 degrees F. This calculation is determined by assuming there is no stratification at the higher velocity, and that the SOS spread is just the tolerance in the meter's absolute reading. In this example the gas temperature was on the order of 70 °F and the ambient was about 85 °F with the sun shining on the piping (no insulation).

Taking the worst-case scenario of a 0.7 °F temperature measurement error, this would translate into an approximate corrected volume calculation error of 0.14% (about 0.2% per degree F). This is a very small error when considering the meter has a flow rate on the order of 3400 CFH at 1.3 fps. The 0.14% error equates to 4.75 CFH error at line conditions. In standard volume, at 750 psig, this error would be approximately 250 SCFH. At \$5 per thousand, this translates into \$1.25 per hour error! Most metering stations probably spend very little time at the lowest flow rates, and thus the total annual revenue at risk is very small when compared to the capital investment needed to reduce uncertainty at the lowest flow rates.

Yes, there is an error in the measurement, but when the magnitude is converted to dollars per hour, one can

quickly see there is very little economic risk due to this uncertainty. Thus, the return on investment (ROI) would probably never pay for the addition of a low-flow meter. While an ROI calculation might be based on the assumption that the addition of a low-flow meter totally eliminates this error, that is an error in itself since any measurement device has uncertainty that might actually not be any lower than the error introduced by the thermal stratification shown here.

The third concern some user's have is the reduction in repeatability of a meter when operated at these low velocities. USMs will typically exhibit less repeatability at lower flow rates, and some may argue this adds to the uncertainty of the facility. To help understand this, let's look at a 16-inch meter recently calibrated to a low velocity of 0.5 fps.

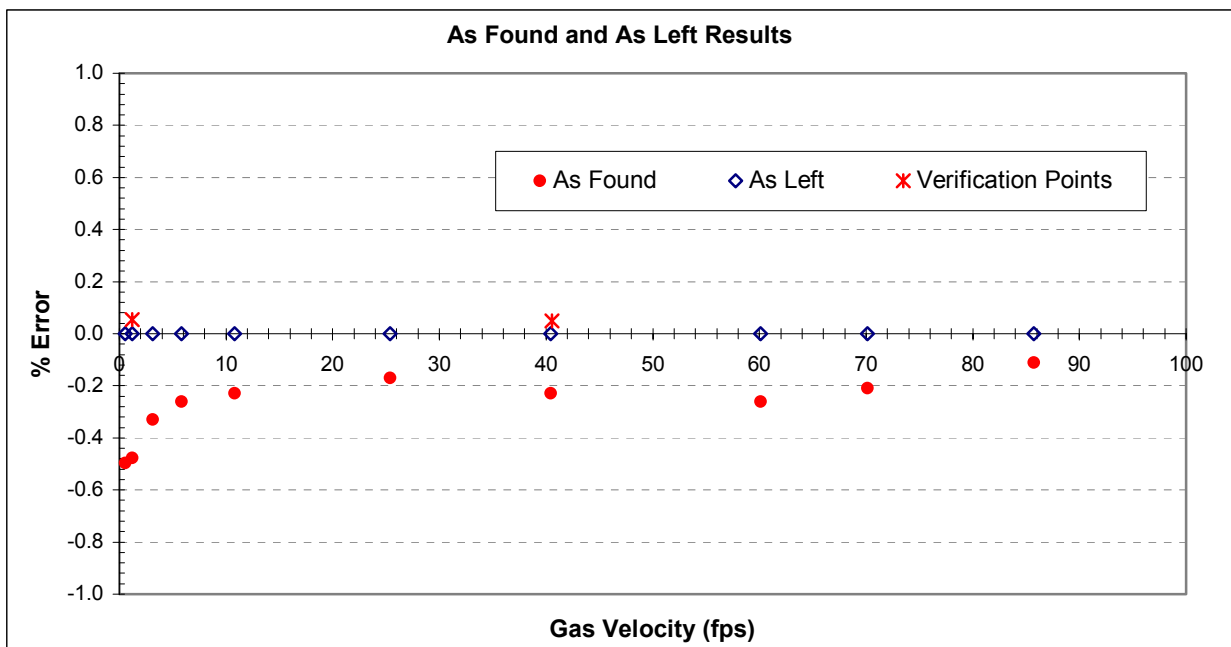

Graph 3 – 16-inch Meter Calibration Results

As can be seen in Graph 3, this 16-inch meter was calibrated from 0.5 fps to 85 fps. After calibration, and implementation of the PWL coefficients, it was verified at two velocities, 35 and 1 fps. The meter repeated to within 0.05% of the predicted error at both velocities. Thus, this meter showed a high degree of repeatability even at this very low flow velocity. It is important to notice that the meter's accuracy, prior to the application of PWL, was not significantly different at the 0.5 fps when compared to the 1.0 fps. Thus, if this meter were operated below 0.5 fps, it would most

likely provide accuracy well within AGA Report No. 9 requirements of $\pm 1.4\%$ to a velocity well below 0.2 fps.

Operating a 16-inch meter at 0.5 fps may permit some type of thermal stratification that could impact the meter's accuracy. Let's take a look at what the SOS spread looked like at the time of calibration on this meter to determine if any significant uncertainty occurred.

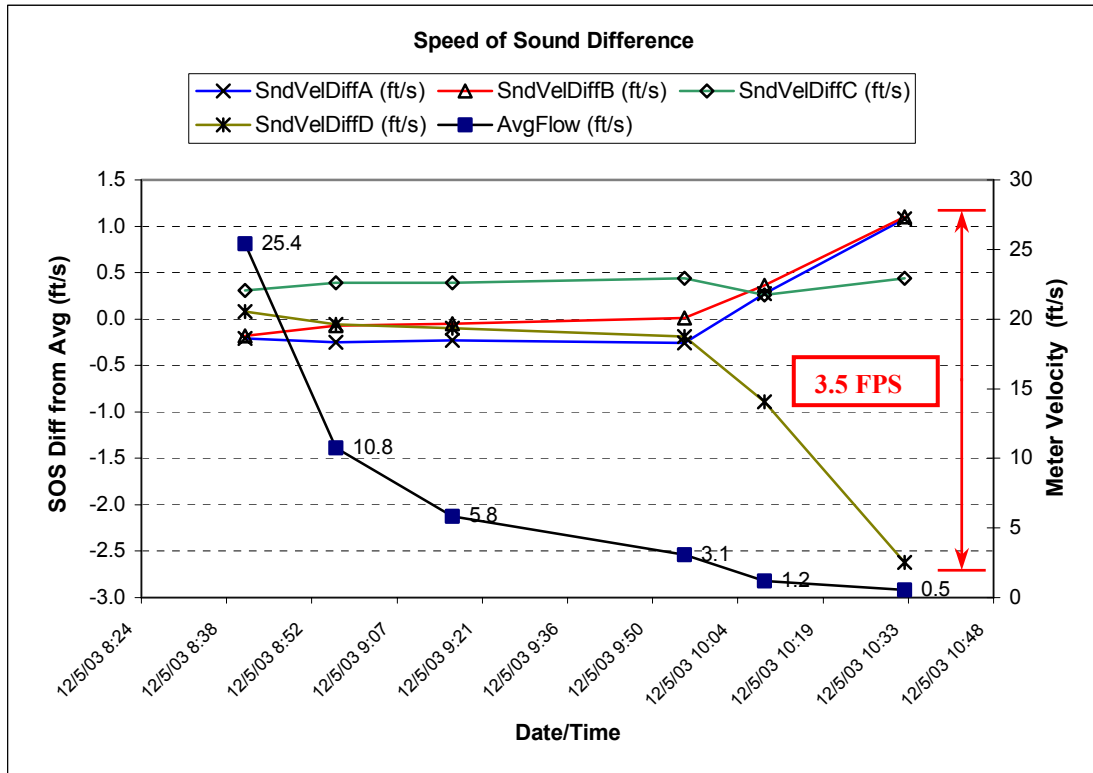

Graph 4 – 16-inch Meter SOS Spread

This trended file shows all the gas velocities at the time of calibration from 25 fps to 0.5 fps. At velocities of 3 fps and above it is clear that the spread of SOS does not change. This indicates no thermal stratification is occurring. At 1.2 fps gas velocity we can see some spread with the bottom Chord D showing about 1.3 fps less SOS than the upper 3 chords. At 0.5 fps there is about a 3.0 fps change in the SOS of Chord D when compared to Chords A, B & C at the lower velocities (3.5 fps peak-to-peak). Thus, some additional thermal stratification occurred at 0.5 fps as compared to the 1.2 fps data point.

One would then think that there is some additional uncertainty in the measurement due to thermal stratification, and that is probably true. However, it is interesting to note that only 13% of the gas volume is measured by Chord D. In other words, about 87% of the gas was still at the same approximate temperature, and the RTD element was measuring the temperature where most of the gas was flowing. Let's also look at the velocity profile of each chord on this meter at the three lowest velocities and see if they are changing, and if so by how much.

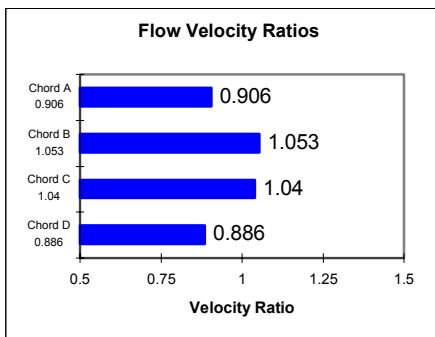

Graph 5 – Chord Ratios at 3.1 fps

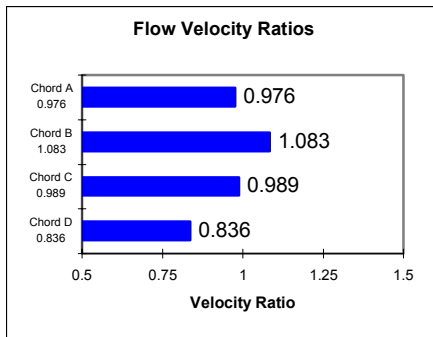

Graph 6 – Chord Ratios at 1.2 fps

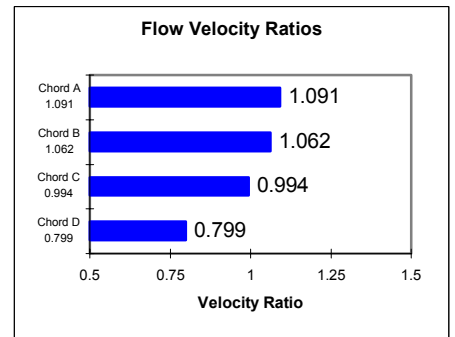

Graph 7 – Chord Ratios at 0.5 fps

From Graph 5 we can see the typical, symmetrical velocity profile. Both Chords A & D are close to the ideal value of 0.89, and Chords B & C are close to the ideal 1.04. As the velocity is reduced, shown in Graph 6, to 1.2 fps, we can certainly see a bias of higher gas velocity at the top of the meter than at the bottom. The cause of this velocity profile distortion was discussed in a paper presented at the 2003 Southeast Asia conference [Ref 7]. Essentially the gas at the top of the meter is hotter, resulting in internal convection currents distorting the velocity profile. As the average gas velocity is reduced to 0.5 fps, we can see even more distortion in the velocity profile entering the meter.

The important thing we can derive from this is that even with this distortion in the gas velocity profile, the

basic error of the meter was relatively unchanged. The amount can be determined by looking at the error plot in Graph 3. Notice the three low-velocity data points are all with 0.2%. So, even with some thermal stratification at low velocities, and a corresponding velocity profile change, the impact on the meter's uncorrected accuracy is relatively minimal, especially when considering the dollar value of the gas at these velocities.

Of course the errors plotted in Graph 3 are the average of several data points. One could argue that the scatter is much larger, and the individual readings just happen to average close to zero. Let's look at the scatter of each reading used to determine the final value in order to determine just how repeatable it was on each of the 120 second runs at the two verification points.

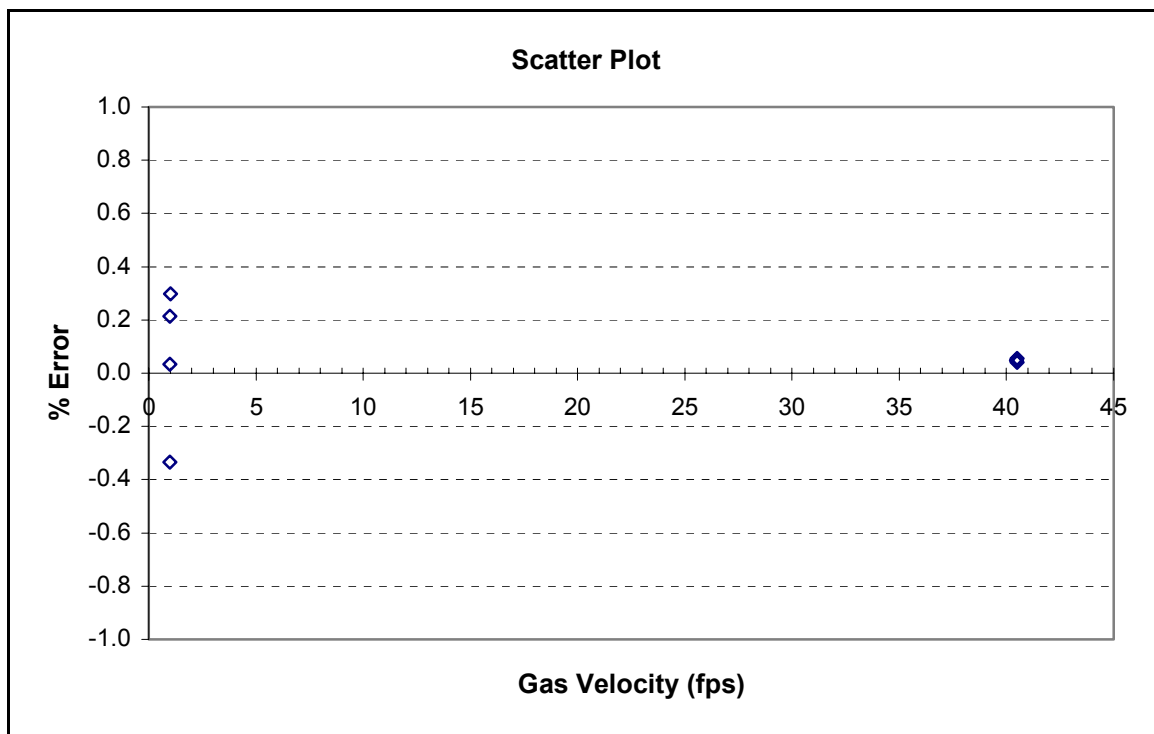

Graph 8 – 16-inch Scatter Plot Data

Graph 8 is a scatter plot of the 16-inch meter taken from the two verification points. It is easy to see that the meter was extremely repeatable at the 40 fps point. The total spread of data was $\pm 0.007\%$ (there are actually three data points there)! At the 1 fps point the spread of data was about $\pm 0.3\%$. Three of the four runs at 1 fps were just barely outside the repeatability requirement as described by AGA 9 for the high

accuracy region, with the fourth virtually on zero. Thus, even when this meter is operated at 1 fps, the repeatability of this meter was very good.

Let's use this 16-inch meter as an example for cost savings based upon low-flow performance. Suppose a site had an operational range of 425 MMCFD to 5 MMCFD at 750 psig. If the designer selected an operational range of 5-70 fps, this would require a 6-

inch meter to handle the lower flow rate at 5 fps. At 5 fps the 16-inch meter could handle approximately 31 MMCFD. However, the designer might decide to install a mid-size meter since there would not be much “dead-band” between the upper limit of the 6-inch meter (70 MMCFD) and the lowest the 16-inch would be operated. This would mean that a 10-inch meter would probably be selected to handle the middle range of flow and provide ample “dead-band” when closing the 16-inch run, or closing the 6-inch run.

Looking at the economics of adding two additional smaller meters in this scenario, the added cost could easily exceed \$150,000 when including the headers, valving, meter runs, RTU and actuators needed to sequence the 6 and 10-inch meters. A single 16-inch meter could be used for this example by operating it at 0.8 fps (in lieu of the traditional lower 5 fps limit), substantially cutting capital costs, and certainly reducing the long-term O&M costs. Perhaps there would be some increased uncertainty as was presented in the previous 12-inch example. However, even if the uncertainty were assumed to be $\pm 0.25\%$, this would translate into only ± 500 SCFH, or about $\pm \$2.50$ per hour. Thus, there is probably not enough of a potential reduction in measurement uncertainty to justify spending \$150,000.

Dual or Multiple Meter Runs

For larger applications, many designers choose to use two similar sized meters in parallel. The break point often comes when the flow rate dictates a meter size of 16-inch and above. Many variables must be considered before choosing whether one meter is a better solution, or if two might be the best choice.

Two meters provide some redundancy. This might be important if company policy dictates removal and re-calibration periodically. Also, if maintenance policy requires internal inspection periodically, having two runs makes it much easier to perform this task without having to estimate volumes. Additionally, should one meter develop an operational problem, having a second meter may help identify the problem(s).

The disadvantage of using two meters is obviously the capital cost and additional maintenance required. Two smaller meters will require more capital expense in the beginning, and most likely more long-term O&M cost. Which design is best for any given application

somewhat depends upon the operational requirements, space limitations, flow rangeability, and other factors.

Generally speaking, designers that choose to use two or more meters in parallel don't do it for rangeability requirements. Today's USM provides at least 30-1 rangeability, and many are flow calibrated to achieve in excess of 80-1 rangeability. The primary reason is for redundancy and to permit removal of a meter for maintenance while measuring all station flow through the other meter(s).

Basic Piping Issues

As with any other technology, ultrasonic meters require adherence to basic installation guidelines. Recommendations related to the installation of primary metering elements, such as the orifice and turbine, have been in place for a long time. These are provided through a variety of standards (API, AGA, ISO, etc.) to insure accurate performance (within some uncertainty guidelines) when installed. The reason for these guidelines is that the meter's accuracy can be affected by profile distortions caused by upstream piping. One of the benefits of today's USM is that it can handle a variety of upstream piping designs with less impact on accuracy than other primary devices.

Installation effects on measurement devices have been studied in much more detail than ever before. This is due in part to the available technology needed for such evaluation. Much of this research has been focused on ultrasonic meters. Reducing uncertainty has also become a higher priority for pipeline companies today due to the increasing cost of natural gas. Designing an ultrasonic meter station that provides the same installed accuracy as that at the time of calibration is very important.

According to research work performed at Southwest Research Institute (SwRI) by Terrance Grimley, it would take a minimum of 100D of straight pipe for a profile with high swirl to return to a fully symmetrical, fully developed, non-swirling velocity profile [Ref 5]. More complex upstream piping, such as two elbows out of plane, create even more non-symmetry and swirl than this model shows. Today's USM must handle profile distortion and swirl in order to be accurate and cost-effective. As with orifice and turbine meters, however, installation guidelines must be followed to achieve a predictable accuracy.

In 1998 AGA released AGA Report No. 9. This document discusses many aspects and requirements for installation and use of ultrasonic meters. Section 7.2.2 specifically discusses the USM's required performance relative to a flow calibration. It states that the manufacturer must "Recommend upstream and downstream piping configuration in minimum length – one without a flow conditioner and one with a flow conditioner that will not create an additional flow rate measurement error of more than $\pm 0.3\%$ due to the installation configuration." In other words, assuming the meter were calibrated with ideal flow profile conditions, the manufacturer must then be able to recommend an installation which will not cause the meter's accuracy to deviate more than $\pm 0.3\%$ from the calibration once the meter is installed in the field.

During the past several years a significant amount of testing was conducted at SwRI in San Antonio, Texas to determine installation affects on USMs. Funding for these tests has come from the Gas Technology Institute, formally known as the Gas Research Institute (GRI). Much of the testing was directed at determining how much error is introduced in a USM when a variety of upstream installation conditions are present. This was presented in a report at the 2000 AGA Operations Conference in Denver, Colorado [Ref 5].

From the test results one can conclude that upstream piping (elbows, tees, etc.) does have an effect on the meter's performance. One meter passed the installation affects test with no flow conditioner when located 20D from the effect. Nevertheless, most users still choose to use a flow conditioner in order to reduce upstream piping effects and the potential impact on measurement accuracy.

Which brand of flow conditioner to choose often depends upon the user's preference. From the SwRI report the results indicate that several brands and styles of flow conditioners work well. The only exception is that 19-tube bundle as the test results are inconsistent, and generally not as good as other flow conditioners. Thus, USM manufacturers generally do not recommend their use.

Piping Recommendations

When AGA 9 was released in 1998, it did not include any recommendations for upstream or downstream

piping lengths. At that time the GTI installation affects data was not available. Rather than specify any minimum requirements, it was decided to allow each manufacturer to specify their recommendation based upon their meter's design and performance. With the data that is available today, most users have now adopted their own company standards. Although the standards vary from company to company, most utilize a more conservative approach to insure the best possible measurement performance in the field.

Although AGA 9 is currently being revised, no minimum piping recommendation has yet been agreed upon. The following is an example of some transmission company standard designs that perhaps will become the minimum recommendation in the future.

For uni-directional applications many users are now standardizing on 15-20 nominal diameters of pipe upstream, and a minimum of 5 nominal diameters downstream. Initial work done at SwRI used this piping length for some flow conditioner designs. However, for a variety of reasons, including reducing uncertainty, more emphasis has been placed on standardizing with 20D upstream. The downstream section is usually 5D, or longer if several thermowells or other taps are required. It's not uncommon to see a downstream section that is 6-8 diameters in length.

The upstream section is usually comprised of two spoolpieces with a flow conditioner located in the middle. Some flow conditioner designs require two components. The perforated plate component is generally located 10D from the meter, and the second component is located at the inlet of the spool piping, or 15-20D from the meter for designs that utilize two 10D spools. By using the 20D design, regardless of the selection for flow conditioner, the overall length of the meter run essentially remains the same.

It should be noted that installing the flow conditioner at the aforementioned locations is not necessarily consistent with the recommendation of the flow conditioner manufacturers. This will, however, exceed the manufacturer's minimum requirements. Figure 1 shows a typical minimum piping design using a flow conditioner with a 5D and 10D upstream spool pieces, and a 5D downstream spool piece.

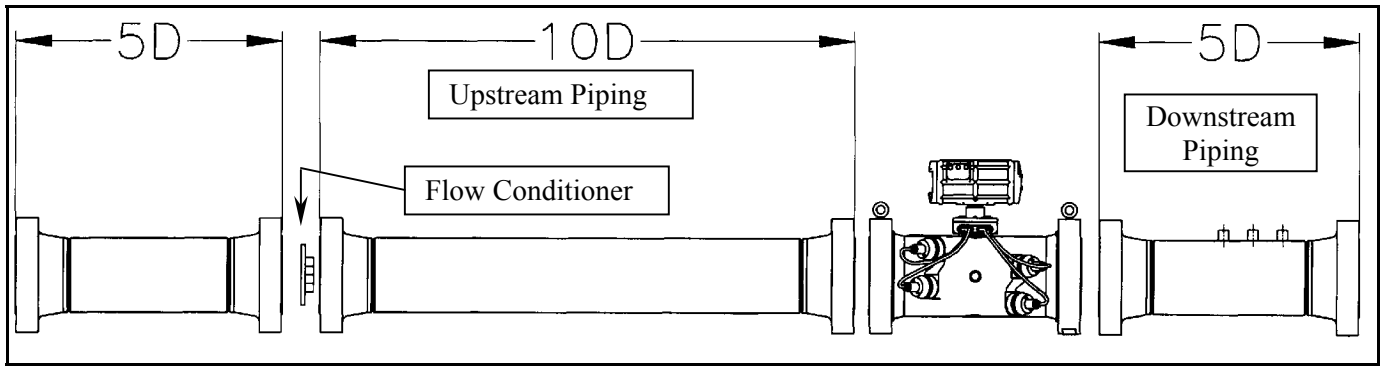

Figure 1 – Typical Uni-Directional Piping Design

The location of thermowells is discussed in Section 7.2.5 of AGA 9. It states that the thermowell should be located 2-5 nominal diameters downstream of the meter. The reason for locating it close to the meter is for the same reason as other primary devices – to insure the temperature at the RTD is the same as in the meter. For bi-directional applications, a potential issue arises. AGA 9 currently states the RTD should be at least 3D from the meter. This is to minimize the effect turbulence (caused by the protrusion at the inlet to the meter) may have on the meter’s accuracy.

Since the wording related to the RTD location in bi-directional applications was not as specific (i.e. 3D – 5D) as that for uni-directional application, some designers have taken this to mean it can be located 10-15D from the meter. The reason some have chosen to locate the RTD at 10-15D is the concern about any wake-turbulence from the thermowell affecting the meter’s performance. In their opinion, locating the thermowell at 3-5D upstream of the meter would cause a measurement error. However, this isn’t the case.

SwRI conducted tests with thermowells located at distances ranging from 1D to 5D upstream on more

than one manufacturer’s 8-inch ultrasonic meter. Results showed no measurable effect when the thermowell was at 3D, with only a slight influence at 2D. From this testing AGA 9 adopted the recommendation of a minimum of 3D upstream. Installing thermowells outside of the flow conditioner area (much further than 5D from the meter) may cause measurement errors.

When the thermowell is located at some distance (10-15D) from the meter, there is the risk of having a differential gas temperature between the meter and the RTD. If the RTD is downstream of a flow conditioner, there will be a Joule-Thompson effect that will change the gas temperature. Some designers have chosen to resolve this by using a dual-input averaging temperature transmitter. Calibration of a dual-averaging unit is more difficult, and creates potentially more work. Thus, it is recommended that thermowells be located between 3-5D and to use a 10D spoolpiece between the meter and the flow conditioners (on both the upstream and downstream side) in bi-directional metering applications. Figure 2 is a typical design used for bi-directional applications.

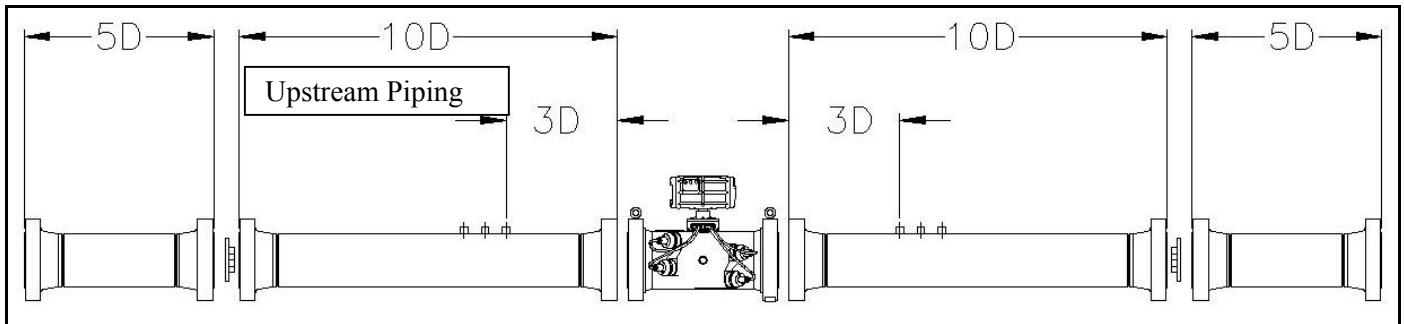

Figure 2 – Typical Bi-directional Piping Design

Some designers install a tee upstream and downstream of the meter run. The purpose of the tee is to permit easy inspection inside the meter run. The addition of a tee, rather than an elbow, has long been used on orifice meters. However, some feel the introduction of a tee upstream of the meter creates a more distorted velocity profile. Although flow conditioners do a very good job of minimizing distorted flow profiles, none are perfect. One can think of a flow conditioner like a shock absorber is to a car – they dampen but do not remove the disturbances.

At present there is very little published data to show how a tee might impact the accuracy of a meter. Some preliminary data has shown that the use of a tee upstream of a meter with a high-performance flow conditioner probably does not affect accuracy by more than 0.1%. If a tee is to be used upstream of an ultrasonic meter, it is probably a good idea to calibrate the meter with the tee installed to minimize any potential impact.

Other Piping Issues

Using filters upstream of ultrasonic installations is often a subject of discussion. Many designers use filters to remove debris that may be traveling down the pipeline. However, due to the non-intrusive design of an ultrasonic meter, small particles generally pass through the meter with little or no damage. Also, some ultrasonic designs have transducers that don't protrude beyond the meter's wall, reducing the chance that flying debris will erode or damage them.

Another concern relates to the impact that any potential buildup on the inside of the meter and associated piping will have on measurement accuracy. Using a filter or strainer may seem like a proper method of eliminating any potential coating or debris contamination that may occur. However, they may become a high maintenance item with the potential of becoming clogged if there is any significant amount of oil or particles present. Assuming there is no oil or grease, particulates will just pass through the meter.

Another problem is the disintegration of the filter or strainer should it become clogged. Part of the element may lodge against the flow conditioner. This will impact the conditioner's operation, and most likely effect the meter's accuracy. Although this can easily be identified by observing path velocity information it will require disassembly of the meter run to remove

the foreign material. For these reasons, and the issue of cost and additional space requirements, and the added pressure drop, most designers do not use filters for ultrasonic metering applications.

Control Valve Noise

One aspect to keep in mind when designing an ultrasonic meter station is the use of control valves (regulators). Ultrasonic meters rely on being able to communicate between transducers at frequencies typically in excess of 100 kHz. Control valves can generate ultrasonic noise in this region. The magnitude of this ultrasonic noise depends upon several factors, including the type of valve, flow rate and differential across the valve.

Meter manufacturers have different methods for dealing with control valve noise. Whenever an ultrasonic meter is used in conjunction with a control valve, the meter manufacturer should be consulted prior to, or during the design phase, to ensure that the final design minimizes or eliminates any impact that could potentially reduce measurement quality.

Although designers prefer locating the control valve relatively close to the meter to minimize the facility's footprint, the drawback is that ultrasonic noise from the valve may interfere with the meter's operation. The use of tees between the meter and the control valve to isolate control valve noise is very common. The actual design, number of tees, and location of meter relative to the control valve depends upon many variables. While elbows do provide some attenuation, tees provide at least twice as much.

Manufacturers of USMs incorporate different electronic approaches to help deal with control valve noise. Some use higher frequency transducers while others utilize digital signal processing to help reduce the effects of the extraneous noise. The key in each of these approaches is to improve the signal to noise ratio, although additional attenuation, through the use of one or more tees, and distance, may still be required.

Figure 3 is a drawing depicting a typical method of installing a single tee. The use of a "dead-end" cap, with a 2D spoolpiece on the tee, has been shown to provide additional benefits in isolating control valve noise. In this design the control valve is downstream of the tee. Often times a single tee can provide the necessary isolation from a control valve.

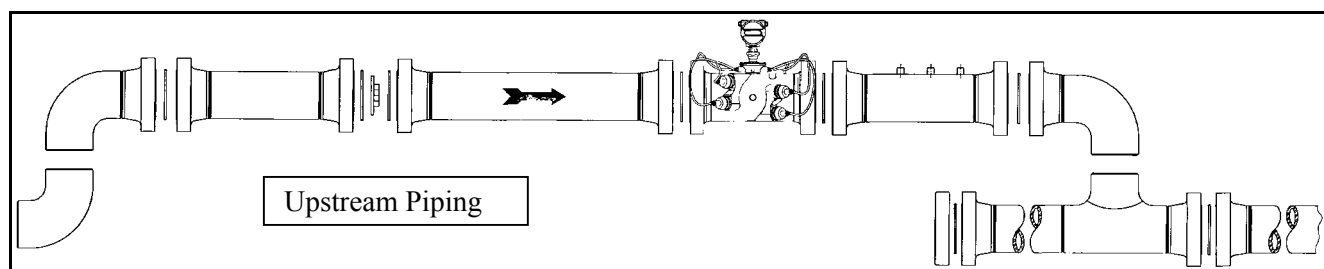

Figure 3 – Piping with One Tee and Control Valve Downstream

For applications of higher differential pressure applications (perhaps above 300-400 psid), two or more tees may be required. Figure 4 is a drawing showing two tees for this type of application. If given

a choice in using two tees, or moving the control valve further away, the choice should always be to move the valve further.

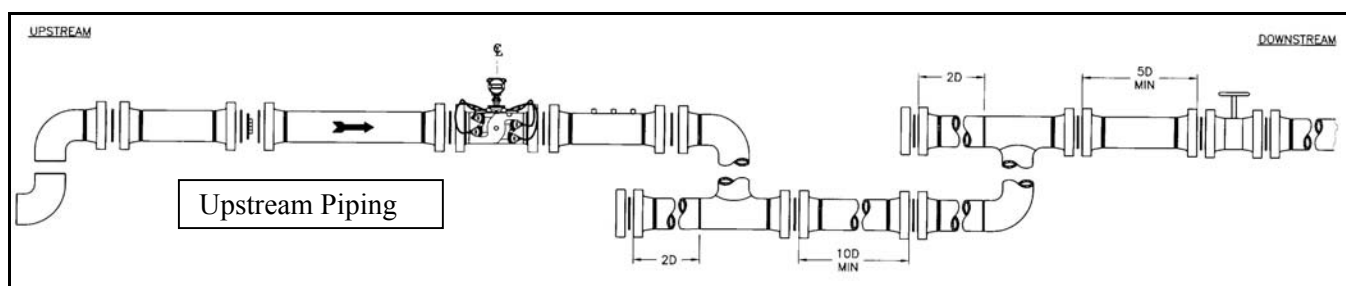

Figure 4 – Piping with Two Tees and Control Valve Downstream

In conclusion, it is a fact that control valves can create enough ultrasonic noise to potentially overpower the USM’s signal. Thus, they should not be located next to the meter as has been done for turbine and orifice meters, and should be installed downstream of the meter, if possible. Locating the valve downstream will result in a higher pressure upstream at the meter. The denser gas at the USM will result in a stronger signal from the transducers, making it easier to differentiate the meter’s signal in the presence of extraneous noise. As stated earlier, tees between the meter and the control valve provide approximately twice the noise attenuation when compared to elbows. A more detailed discussion on how to design USMs with control valves was presented in a paper at the Western Gas Measurement Short Course [Ref 6].

Testing of USMs with control valve noise is ongoing with all manufacturers. Better methods of handling extraneous noise are constantly being developed. The most important thing to remember is to consult with the meter manufacturer before or during the design phase.

Flow Calibration Basics

The primary use for USMs today is custody measurement applications. As was discussed earlier, the introduction of AGA Report No. 9 has helped spur this growth. Section 5 of AGA 9 discusses performance requirements, including flow calibration. Currently AGA 9 does not require meters be calibrated for fiscal use, but it is expected to be required in the next revision. In the absence of a calibration requirement, AGA 9 does require that...“the manufacturer shall provide sufficient test data confirming that each meter shall meet these performance requirements.” The basic accuracy requirement is that 12-inch and larger meters be within $\pm 0.7\%$, and 10-inch and smaller meters to be within $\pm 1.0\%$ for the flow range of q_t to q_{max} (low flow rate to maximum flow rate). Below q_t , the error limit is $\pm 1.4\%$. These maximum error values are “prior” to flow calibration.

Initially USMs were installed without a flow conditioner. However, customers are using flow conditioners in the majority of applications today. Many feel that using a “high performance” flow

conditioner (not a 19-tube bundle) further enhances performance. Even though data exists to support the supposition that some USMs perform quite well without flow conditioners, the added pressure drop and cost is often justified by assuming uncertainty is reduced. One thing that most everyone does agree upon is that if a flow conditioner is used with a meter, the entire system should be calibrated as a unit.

It should be noted that one of the benefits of the ultrasonic meter is that it does not create a pressure drop. The pressure drop resulting from the flow conditioner is offset by the lack of pressure drop across the meter (when compared to orifice or turbine meters). As such, total pressure loss across the metering facility as a result of using flow conditioner is probably no greater than with other primary devices for the same given flow rate.

Most companies have standard designs for their meters that typically specify piping upstream and downstream of the flow conditioner(s) and meter. Usually these USMs are calibrated as a unit with either 3 or 4 piping spools. Calibrating as a unit helps insure that the accuracy of the meter, once installed in the field, is as close as possible to the results provided by the lab.

Most customers feel their applications deserve, and require, less uncertainty than the minimum requirements of AGA 9. To ensure these higher standards are met, virtually all users are flow calibrating their USM meters used in custody transfer applications. At the 2002 AGA Operations Conference a paper was presented that discussed the benefits of flow calibrating ultrasonic meters [Ref 8]. Summarizing from that paper, there are three main reasons users are calibrating meters:

- Reduce uncertainty
- Verify performance
- Improve rangeability

Calibration Labs

There are several flow labs in North America that provide calibration services. Each will calibrate to any number of points the designer feels is necessary. Typically most designers are requesting 6 to 8 data points. Once all the “as-found” data points have been determined, an adjustment factor (or factors) is computed. Facility personnel enter the value(s) into the meter. Usually one or two verification points are

used to validate the predicted “as-left” performance. That is, the lab will select one or two flow rates and verify the meter error is zero (or very close to zero). Generally the USM will repeat within $\pm 0.1\%$ of the predicted value, with more recent results showing verifications typically on the order of $\pm 0.05\%$.

During the late 1990’s two large-capacity calibration facilities were commissioned in North America. These two laboratories permit users to cost-effectively calibrate larger USMs (greater than 10-inch) to full capacity, thus reducing the uncertainty related to measurement error.

Even with the substantial amount of data USM manufacturers have that shows meters to be linear to better than $\pm 0.2\%$, many users want to reduce this error further. As a consequence, some users have implemented multi-point linearization, within their flow computers, to further reduce the uncertainty of their USM calibration results. This is not a new technique and has been often used for turbine meters in the past.

When using this multi-point linearization technique, external to the measurement device, at least two issues always surface. First, since this method has been traditionally applied in the flow computer, the output signals from the USM (serial, frequency and analog) are not adjusted. If the output signal from the meter is sent to two separate flow computers, care must be taken to ensure both computers are utilizing the same algorithm or their results will differ. Second, since the linearization is not taking place in the meter, there is no verification (such as a laboratory calibration certificate) of the linearization process, or the results it generates. This was discussed in more detail in an AGA 2002 paper titled “Benefits of Flow Calibrating Ultrasonic Meters [Ref 8].

Re-Calibration

AGA 9 does not currently require an ultrasonic meter to be re-calibrated (as mentioned earlier, initial flow calibration is not required). As USMs have no moving parts, and provide a wide range of diagnostic information, many feel the performance of the meter can be field verified. That is, if the meter is operating correctly, its accuracy should not change, and if it does change, it can be detected. This, however, remains to be proven.

The use of USMs for custody transfer applications began increasing rapidly in 1998. Thus, with little more than 6 years of installed base, there is limited information to conclude USMs don't require re-calibration. Many companies are not certain as to whether or not they will retest their meters in the future. They are waiting for additional data to support their decision. Manufacturers are also trying to show the technology may not require re-calibration.

During the next several years, many meters will require re-calibration in Canada. Their governmental agency, Measurement Canada, requires USMs to be re-tested every 6 years. Many meters will be due for re-testing in 2004. Once data is obtained from these meter re-calibrations and from random re-testing by customers, and long-term data from meters at calibration labs is analyzed, the need for recalibration can be better assessed.

Several users have removed meters in the past year and returned them to the calibration facility for a quick verification. If the meter is clean, the performance on these has typically been within 0.1-0.3%. Unfortunately, there is very limited information to date that has been published. Over the next few years, the industry's knowledge base with respect to the long-term accuracy of the ultrasonic meter should grow significantly.

Some designers have chosen to incorporate a separate "reference" meter in their larger stations [Ref 9]. The purpose of this meter is to provide an in-situ verification against all the other fiscal meters at that location. The idea is to route all the gas from a given operational meter periodically through the "reference" meter and make any adjustment based upon the difference. In many ways this is exactly what the calibration facility is doing. However, this technique has several issues that must be addressed.

First, if there are any installation effects on the reference meter, a bias could be introduced in the results. The installation effect could come from the upstream piping or pipeline contamination. Second, the addition of a reference meter adds significantly to the cost of the station. Not only is the designer paying for the additional reference meter, there is an additional cost for each meter run as a separate ball valve must be included to permit diverting the gas through the reference meter. Additionally, the extra reference run requires more space on the skid. Also,

using a reference meter on location somewhat limits the ability to verify performance over the entire range of operation. Finally, removing a meter and having its performance verified at a calibration facility provides an independent analysis of the meter's performance. This would most likely be required in the event of a dispute by the purchaser of the gas.

Other Design Issues

EMI/RFI

The USM is electronic in nature. As such some believe it is susceptible to electro-magnetic interference (EMI) from high voltage power lines. Today manufacturers enclose electronics in well-shielded metal housings that are virtually immune to any typical field EMI problems. Installations have been done where 200,000+ volt AC power lines are virtually overhead of the meter with no impact on operation.

Radio frequency interference (RFI) can also affect electronic devices. Again, all manufacturers provide a high degree of protection by enclosing the electronics in grounded metal housings. However, the designer is cautioned to insure that all the wiring that is attached to the meter is also grounded. There have been reported cases where high-power radio transmitters, such as Ham radios, can interfere with a meter's operation. By installing shielded wiring, and following proper grounding recommendations, this potential problem can be eliminated.

Communication issues

Most USMs communicate using either RS-232 or RS-485. However, today more and more products include Ethernet connectivity. By using Ethernet, much more data is available in a very short period. Some USM designs permit collecting special files that are only available via Ethernet. For that reason many users are now installing CAT 5 wiring from their measurement buildings to the USM. One additional benefit of using Ethernet communication over serial is that several computers can talk to the USM simultaneously with no impact on the meter's operation, or on the other computers. This is beneficial when the user is performing routine maintenance and their end customer would also like to obtain data from the meter. This type of data collection is not possible with a single serial data port.

The general recommendation for serial communication varies by designer. For distances up to 250 feet, serial communication has been shown to be very reliable, depending upon baud rate. This distance is substantially longer than the 50-foot limitation that used to be the standard maximum recommended length. Using a low-capacitance cable, specifically designed for data communication, is very important to insure quality serial, RS-232 communication when data rates exceed 9,600 baud.

The actual maximum distance is somewhat dependent upon communication speed. That is, for higher speed communication (beyond 9600 baud) the reliability may be less, necessitating shorter lengths, or switching to RS-485. For this reason, designers generally choose to use RS-485 for lengths in excess of 250 feet. Here the distances can easily be several thousand feet with no degradation in communication performance. For distances of 50-100 feet, RS-232 can easily operate at 38,400 if the proper data communication wire is used.

Another feature many designers take advantage of is the ability to remotely access a meter. Some USM manufacturers provide software that supports remote, dial-up access. When using a meter that provides Ethernet connectivity, remote access becomes even easier if the site has wide area network (WAN) access. With this type of communication a technician can be on a computer, virtually anywhere in the world, and communicate directly to the USM, via the Internet. The Ethernet connection provides tremendous bandwidth capabilities and also permits more than one computer to communicate simultaneously with the meter. Even if the site does not have Internet access via a WAN, some users still install the wiring and also an Ethernet hub. This permits several laptops to simultaneously communicate with the meter with no interference with each other.

A common remote access strategy is to attach a USM serial port to a modem. Although slower than the Internet, it does permit remote monitoring and troubleshooting without the need to for a site visit. When designing an ultrasonic meter installation, consideration should always be given to providing remote access as it can often provide substantial savings for a small monthly investment. Since other equipment at the measurement site, such as gas chromatographs and flow computers, also support remote access, either via Ethernet or serial

communications, it is not uncommon for all three to be accessed through the same phone line.

Ambient Temperature

Today's USM is designed to handle a wide range of ambient temperature conditions. Electronics typically can operate from -40 °F to at least +140 °F. Thus, the meter can be installed in most applications without the need for a shelter or building. If the designer has an application where temperature extremes are present, a shelter may typically be included more for the technician's benefit than the meter's requirement.

Power

Most applications today utilize remote AC power to provide 12 or 24 volts DC to operate their USM rather than solar or thermal electric generators (TEG). Although solar and TEG are feasible, the typical installation also has other "higher-power" consumption components such as flow computers, gas chromatographs and communication equipment.

As with all electronic devices, providing a reliable power source is important. Designers typically utilize an uninterruptible power supply (UPS) to insure reliable service. Some USM manufacturers provide power loss alarms in the meter's audit history. This can be very helpful in the event of intermittent power problems. First, it indicates there is a problem by logging an alarm. Second, by knowing the date and time of the event, determining the amount of downtime can assist in estimating the volumes missed. Also, knowing the date and time may be helpful in solving the power problem.

Pulsation

One problem for just about any measurement device is how accurate it performs when subjected to pulsation. The effect of pulsation on orifice meters has been studied for years, and many reports have been written. As the USM is a non-intrusive device, it might be assumed there would be little effect on its accuracy. However, this may not always be the case.

Some independent testing has been performed on several brands of USMs. To date very little has been published. However, it is safe to say that pulsation, given the right conditions, can impact the accuracy of an USM. More research is being done on this area, and it's expected results will be published in 2004.

Pressure Effect Issues

No discussion on calibration of USM would be complete without bringing up the issue of calibrating at one pressure and operating at another pressure. Testing conducted at SwRI, under the funding of the Gas Technology Institute (GTI), has shown some potential for a meter's performance to shift with pressure [Ref 10]. Additional testing is on-going and some separate tests have not supported this conclusion. At the present time the industry is trying to resolve this issue.

The results for different manufacturers do show somewhat different pressure effect results [Ref 11]. Currently USM manufacturers feel there is no pressure effect. Each has conducted testing at other facilities to show there is little, if any, effect. However, the issue remains. Perhaps later in 2004 this will be resolved. At present the pressure effect, if there is one, is probably not more than 0.2-0.3% for meters calibrated at 1000 psig and operated at 200 psig. Since most transmission companies typically operate above 600 psig, calibrations done at the high-capacity facilities probably don't introduce any significant bias.

Dirty Meter Considerations

Just like any measurement technology, if the meter is not properly maintained, performance will suffer. Today's pipelines are generally relatively clean. However, there is always the potential for mill-scale and oil to coat the inside of a meter. This coating will impact the accuracy. The magnitude and impact on accuracy appears to be somewhat dependent upon meter design. Several papers have been published on this issue [Ref 9, 12 & 13]. The good news here is that USMs are probably much less sensitive to performance changes due to contamination than other technologies. Maintaining a clean primary measurement element is just as important as calibration of ancillary devices. Many users have regularly scheduled inspections to insure optimum performance.

Today's powerful software also makes it much easier to identify potentially dirty meter conditions. By collecting the data from the USM, indications of pipeline buildup can often be identified. Other issues, such as partial blockage of a flow conditioner, can easily be seen using the proper diagnostic techniques. The ability to diagnose potential problems, even remotely, is certainly one of the major benefits in using USMs, and should not be under-estimated when designing a station.

In a paper published at the 2003 AGA Operations Conference, examples were shown on how a meter's performance can be diagnosed using software [Ref 14]. The ability to recognize when problems are developing has helped many users reduce measurement uncertainty over the past several years, and thus lower their Lost and Unaccounted For (LAUF) volume. In many cases this has translated into a significant increase in a company's "bottom-line" revenue.

Conclusions

During the past several years, ultrasonic meters have become one of the fastest growing new technologies in the natural gas arena. Their popularity has increased dramatically because they provide significant value to the customer by reducing the cost of doing business, including capital and O&M costs. The benefits of using USMs have been well documented over the past few years [Ref 3 & 4].

More applications than ever before are being designed today using this technology. Just like any measurement device, it must be installed and maintained properly to insure optimal long-term performance. The best of technologies will not provide the expected benefits if it's not installed and maintained properly. The designer must take into consideration all aspects of the station requirements in order to realize the potential for this technology.

USMs provide a much wider rangeability than other devices, while reducing measurement uncertainty to significantly lower levels. Often fewer meters are required because of this rangeability, further reducing capital and operational costs. This increase in rangeability and improvement in accuracy has often been attributed to the reduction in LAUF most companies have realized during the past 3-5 years.

Today it is not uncommon for designers to operate their USM from 1-80 fps, and obtain accuracy (after calibration) on the order of 0.1% relative to the lab. By extending the operational range from the traditional 5-10 fps at the low velocity region, USM rangeability is now permitting the designer to reduce the number of meters needed thus saving capital dollars that range from \$30K to more than \$100K for larger stations.

Installation effects on USMs from upstream piping, such as elbows and tees, are generally thought to be less than with other technologies. Most customers are

using flow conditioners to minimize the potential impact upstream piping may have on a meter's accuracy. Additionally, virtually all designers are requiring the USM, and all associated meter run piping, to be flow calibrated as an assembly, further reducing uncertainty.

The issue as to whether re-calibration of ultrasonic meters is required has not been answered by most. Measurement Canada currently requires the USM to be tested at least once every 6 years. Other North American customers aren't required to re-calibrate, and most are undecided on the potential added value this may bring. Some designers have opted to install a secondary in-situ transfer standard in the field to verify performance on a periodic basis [Ref 9]. However, most designers feel this method is too expensive and does not provide the necessary traceable certification that might be needed should the buyer of the gas question the accuracy of the primary meter. Thus, if a user is concerned, they generally prefer to remove a meter and return it to the calibration lab for re-verification.

Using an ultrasonic meter in conjunction with a control valve requires special attention. Control valve applications are much better understood today than a few years ago. All manufacturers have methods to deal with this issue, and it varies depending upon design. The manufacturer should be consulted prior to the facility design phase to help insure appropriate design considerations are implemented to minimize adverse effects on meter accuracy and performance.

Today's USM is a robust and very reliable device with many fault-tolerant capabilities. It is capable of handling a variety of pipeline conditions including contaminants in the natural gas stream. In the event of transducer failure, the meter will continue to operate, and some USM designs maintain excellent accuracy during this situation [Ref 8]. When faced with contamination such as oil, valve grease, and other pipeline contaminants, today's USM will continue working and, at the same time, provide enough diagnostic data to alert the operator of possible impending measurement accuracy problems.

Making provisions for remote access to the ultrasonic meter can translate into significant long-term savings. Designing a station to include remote communication not only is a benefit for maintaining the USM, but it can significantly assist in maintaining other measurement equipment.

References:

1. AGA Report No. 9, *Measurement of Gas by Multipath Ultrasonic Meters*, June 1998
2. *Provisional Specification for the Approval, Verification and Installation and use of Ultrasonic Gas Meters*, Measurement Canada PS-G-E-06, 1998-03-05
3. John Lansing, *Basics of Ultrasonic Flow Meters*, ASGMT 2000, Houston, TX
4. John Lansing, *Smart Monitoring and Diagnostics for Ultrasonic Meters*, NSF MW 2000, Scotland
5. T. A. Grimley, *Ultrasonic Meter Installation Configuration Testing*, AGA Operations Conference, 2000, Denver, CO
6. John Lansing, *Ultrasonic Meter Station Design Considerations*, Western Gas Measurement Short Course, 2003, Victoria, BC, Canada
7. Klaus Zanker, *Diagnostic Ability of the Daniel Four-Path Ultrasonic Flow Meter*, Southeast Asia Flow Measurement Workshop, 2003, Kuala Lumpur, Malaysia
8. John Lansing, *Benefits of Flow Calibrating Ultrasonic Meters*, AGA Operations Conference, 2002, Chicago, IL
9. James N. Witte, *Ultrasonic Gas Meters from Flow Lab to Field: A Case Study*, AGA Operations Conference, 2002, Chicago, IL
10. T. A. Grimley, *Performance Testing of Ultrasonic Flow Meters*, AGA Operations Conference, 1997, Nashville, TN
11. Dr. Jim Hall, William Freund, Klaus Zanker & Dale Goodson, *Operation of Ultrasonic Flow Meters at Conditions Different Than Their Calibration*, NSF MW 2002, Scotland
12. John Lansing, *Dirty vs. Clean Ultrasonic Flow Meter Performance*, AGA Operations Conference, 2002, Chicago, IL
13. John Stuart, Rick Wilsack, *Re-Calibration of a 3-Year Old, Dirty, Ultrasonic Meter*, AGA Operations Conference, 2001, Dallas, TX
14. John Lansing, *Using Software to Simplify USM Maintenance*, AGA Operations Conference, 2003, Kissimmee, FL